



ORIGINAL INSTRUCTIONS

EN 15194

BMIEEN22V01



IDEAL BIKES is a brand of NIKOS MANIATOPOULOS S.A.

NIKOS MANIATOPOULOS S.A.
INDUSTRIAL & TRADING CYCLE COMPANY

Kosti Palama & Solonos Str., Agios Vasileios,
26504 Patras, Greece

Tel.: +30 2610 993 045 | Fax: +30 2610 990 424 | Email: sales@idealbikes.gr

© 2022 NIKOS MANIATOPOULOS S.A. | Subject to changes.

Contents

PlusDocu GmbH

Stralauer Platz 34, 10243 Berlin, Germany

info@plusdocu.com | www.plusdocu.com

© Copyright

Text, pictures and information are protected by copyright and are subject to the copyright terms of PlusDocu GmbH.

Duplication, reproduction, translation and any other kind of commercial use of this documentation, in whole or in part, in printed or electronic form, is only permitted with prior written approval.

FRAME



A Top tube

B Head tube

C Down tube

D Chainstay

E Seat stay

F Seat tube

G Suspension fork/fork

PRISMA-810



- | | |
|--|---|
| 1 Handlebar with operating elements | 11 Drive unit |
| 2 Handlebar stem | 12 Rear derailleur |
| 3 Cables/hydraulic cables | 13 Stand |
| 4 Headlight | 14 Rear wheel |
| 5 Front mudguard | 15 Rear disc brake |
| 6 Front wheel | 16 Rear mudguard |
| 7 Front disc brake | 17 Rear light with reflector |
| 8 Front wheel hub | 18 Carrier |
| 9 Semi-integrated battery | 19 Seat post quick-release clamp |
| 10 Pedal drive | 20 Saddle with seat post |

PRISMA-810FX



- | | |
|--|---|
| 1 Handlebar with operating elements | 11 Drive unit |
| 2 Handlebar stem | 12 Rear derailleur |
| 3 Cables/hydraulic cables | 13 Stand |
| 4 Headlight | 14 Rear wheel |
| 5 Front mudguard | 15 Rear disc brake |
| 6 Front wheel | 16 Rear mudguard |
| 7 Front disc brake | 17 Rear light with reflector |
| 8 Front wheel hub | 18 Carrier |
| 9 Fully integrated battery | 19 Seat post quick-release clamp |
| 10 Pedal drive | 20 Saddle with seat post |

OVERVIEW	3
Frame	3
PRISMA-810	4
PRISMA-810FX	5
ABOUT THESE INSTRUCTIONS	10
1 Reading and storing these instructions	10
2 Applicable documents	11
3 Labelling and meanings of safety notices and warnings	11
3.1 Presentation and layout	12
3.2 Hazard classification	12
4 Explanation of symbols and signs	13
5 Product marking	14
SAFETY	15
6 Proper use	15
7 Classification (classification for bicycles usage)	16
8 Misuse	18
8.1 Prohibition of tuning and modifications	18
9 Residual risks	19
10 Safety notices	20
10.1 General safety information	20
10.2 Safety instructions for the e-drive and its components	22
10.3 Safety instructions for cycling in road traffic	26
11 Maximum permitted total weight	27
12 Torques	28
12.1 Overview of tightening torques	29
13 Maintenance and wear	32
13.1 Wear	32
13.2 Replacing components	33
14 Notes on components made of carbon	33
BEFORE FIRST USE	34
15 Familiarise yourself with the pedelec	34
16 Check your pedelec before you start riding	34
17 Setting the optimum sitting position	36

PEDAL DRIVE		37
18	General information	37
19	Chain drive	37
19.1	Method of operation and handling	37
19.2	Wear and maintenance	38
19.3	Cleaning and care	38
SPECIAL CHARACTERISTICS OF THE E-DRIVE		39
20	General/components	39
21	Information on use	41
21.1	Method of operation	41
21.2	Removing and inserting the battery.....	42
21.2.1	Removing and inserting the fully integrated battery.....	42
21.2.2	Removing and inserting the semi-integrated battery.....	45
21.3	Riding without the e-drive.....	45
21.4	Range/route planning.....	46
21.5	Storage and operating temperatures.....	46
21.6	Cleaning and care	47
BRAKES		48
22	General information	48
23	Brake lever configuration	48
24	Warnings for using the brakes.....	49
25	Disc brake.....	51
25.1	Method of operation	51
25.2	Warnings relating to the use of disc brakes	52
25.3	Operating the disc brake.....	53
25.4	Bedding in disc brakes	54
25.5	Checking the disc brake.....	55
25.6	Adjustments.....	56
25.6.1	Adjusting the brake lever.....	56
25.7	Wear and maintenance	57
25.8	Cleaning and care	57

GEAR SHIFT SYSTEM		58
26	General information	58
27	Operating elements.....	59
28	Derailleur system	59
28.1	Method of operation	59
28.2	Operating the derailleur system	60
28.3	Checking the derailleur system	60
28.4	Wear and maintenance	61
28.5	Cleaning and care	61
29	Hub shifting system	62
29.1	Method of operation	62
29.2	Operating the hub shifting system	62
29.3	Checking the hub shifting system.....	62
29.4	Wear and maintenance	63
29.5	Cleaning and care	63
30	Electronic gear shift system	63
WHEELS		64
31	General information	64
31.1	Rims and spokes.....	65
31.2	Tyre types.....	65
31.3	Valve types	66
31.4	Tyre pressure.....	67
32	Pumping up tyres.....	67
33	Regular checks	68
SADDLE		69
34	Adjusting the saddle	69
34.1	Adjusting the saddle height	70
34.2	Adjusting the saddle position	71
HANDLEBAR		72
35	Adjusting the handlebar	72
SUSPENSION FORK		73
36	General information	73
36.1	Method of operation and terms	74
36.2	Spring tension and lock-out function	75
36.3	Wear and maintenance	76
36.4	Cleaning and care	76

OTHER COMPONENTS	77
37 Lights.....	77
37.1 General information	77
37.2 Mounting points	77
37.3 Switching the lights on and off	78
38 Quick-release clamp	79
39 Bell	80
40 Carrier	81
41 Stand	82
STORAGE AND TRANSPORTATION	83
42 Storing the pedelec	83
43 Transporting pedelecs	84
DISPOSAL	85
HOW TO HANDLE THE PEDELEC	86
44 Overview of the operating steps	86
44.1 Preparation	86
44.2 Using the pedelec	87
44.3 Cleaning and maintaining the pedelec.....	87
44.4 Regularly checking the pedelec components	88
45 After a fall.....	89
46 Riding with children.....	89
47 Transporting baggage.....	90
47.1 Using carriers	91
WARRANTY CONDITIONS	92
MAINTENANCE PLAN	94
BICYCLE PASSPORT	96
HANDOVER CERTIFICATE	98
NOTES	99

ABOUT THESE INSTRUCTIONS

1 Reading and storing these instructions



These Original Instructions – referred to in the following as the “instructions” – are part of the scope of supply of this pedelec.

Contrary to standard EN 15194, all electrically power assisted cycles (EPACs*) described here are grouped under the term "Pedelec.**".

Whenever these instructions refer to “pedelec” in general, they mean any of the pedelec models described here.

All illustrations in these instructions are examples; as a result, individual details on your pedelec may differ from those shown in these instructions.

These instructions contain all of the important information on safety and use of your pedelec. They are based on the standards that apply in the European Union.

Before using your pedelec for the first time, please read these instructions and all applicable manufacturer's component instructions, especially safety notices, carefully and completely.

If you do not follow these instructions and all other applicable manufacturer's component instructions, you or other persons could be injured and/or cause damage to property.

Always keep these instructions and all applicable manufacturer's component instructions on hand for further use.

If you pass on the pedelec to a third party, it is essential that you include these instructions and all applicable manufacturer's component instructions.

You can download a copy of these instructions in PDF format from the manufacturer's website.

* Electrically Power Assisted Cycles = EPAC

** Pedal electric cycle = Pedelec

2 Applicable documents

In addition to these instructions, always observe the additionally applicable manufacturer's instructions for the components installed on your pedelec.

Any manufacturer's instructions for other components enclosed with these instructions must also be observed. For example:

- Pedelec: Drive unit, operating element, battery and charger
- Brakes
- Suspension fork and rear suspension
- Gear shift system
- Hubs/quick-release clamps
- etc.

As a supplement to these instructions, these manufacturer's component instructions form an essential part of the scope of the technical documentation for this pedelec.

If you have not received separate manufacturer's component instructions, please contact the manufacturer of your pedelec to ask for a copy.

3 Labelling and meanings of safety notices and warnings

Safety notices and warnings describe hazards that could occur when handling or using the pedelec, and provide instructions on how to avoid such hazards.

The **safety notices** are summarised in the "SAFETY" section.

Warnings are placed next to the step or process from where the potential hazard arises.

In order to use the pedelec safely, it is imperative to heed the safety notices and warnings. Therefore, you must read through all the safety notices and warnings very carefully and take the contents on board in order to avoid risks when handling and using the pedelec.

Safety notices and warnings are indicated as follows in these instructions, based on the possible consequences of failure to observe them.

3.1 Presentation and layout



SIGNAL WORD

Type and source of hazard

Description of the type and source of the hazard.

» Measures to prevent the hazard.

3.2 Hazard classification



DANGER

» The signal word “Danger” indicates a hazard with a high degree of risk: failure to comply with the safety notices and warnings in this category will result in a fatal or serious injury.



WARNING

» The signal word “Warning” indicates a hazard with a medium degree of risk: failure to comply with the safety notices and warnings in this category can result in a fatal or serious injury.

















CAUTION

» The signal word “Caution” indicates a hazard with a moderate degree of risk: failure to comply with the safety notices and warning notices in this category may result in moderate or minor injuries.

NOTE

» The signal word “Note” indicates a hazard that can lead to damage to property: failure to comply with the safety notices and warnings in this category may damage the pedelec or cause other damage to property.

4 Explanation of symbols and signs

 	<p>You must read and observe the instructions.</p>
	<p>This symbol indicates useful additional information on handling and using the pedelec.</p>
	<p>Marking for products that must only be used indoors. WARNING! There is a risk of electric shock if used in a damp environment and in contact with liquids.</p>
	<p>This electrical device corresponds to protection class II: The device has double or reinforced insulation to protect against electric shocks.</p>
	<p>Warning against hot surfaces. WARNING! There is a risk of burns and fire on contact with flammable materials.</p>
	<p>Symbol for direct current (DC).</p>
	<p>Symbol for alternating current (AC).</p>
	<p>Products marked with this symbol meet all applicable European Economic Community regulations.</p>
 	<p>Electrical devices with this marking must not be disposed of with household or non-recyclable waste. Consumers are required by law to dispose of electrical devices with this marking at suitable collection points for environmentally-friendly recycling.</p>
  Li-ion	<p>Any batteries with this marking must not be disposed of with the household or non-recyclable waste. Consumers are required by law to dispose of batteries with this marking at suitable collection points for environmentally-friendly recycling.</p>
	<p>Marking for recyclable materials. Dispose of the packaging according to the type of material. Dispose of card and cardboard in your waste paper container and films in your plastic recyclables container.</p>

5 Product marking

Description of the product marking.

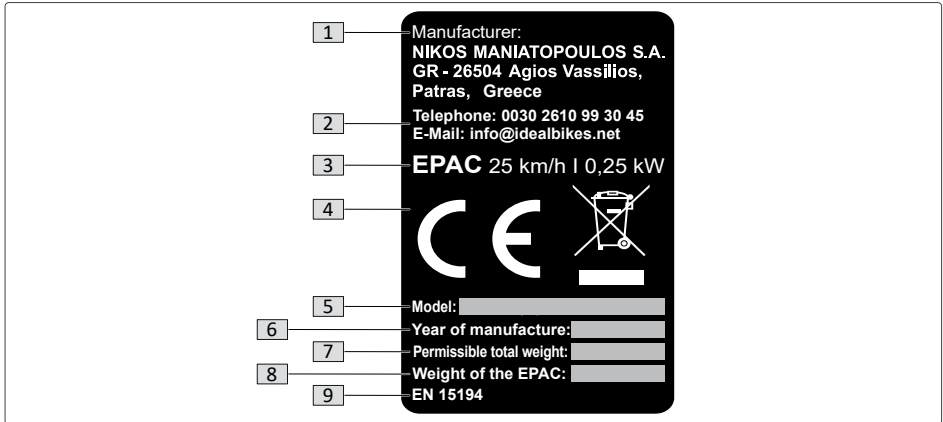

Fig. 1: Illustration of product marking

- 1 Name and address of manufacturer
- 2 Contact information
- 3 Max. motor-driven speed: 25 km/h /
Nominal motor output: 0.25 kW
- 4 Symbols > Chap. 3 on page 11 and > Chap. 4 on page 13
- 5 Model designation
- 6 Year of manufacture/model year
- 7 Maximum permitted total weight***
> Chap. 11 "Maximum permitted total weight" on page 27
- 8 Weight of pedelec (EPAC)
- 9 DIN EN 15194 Cycles- Electrically power assisted cycles- EPAC Bicycles

*** The maximum permitted total weight of the pedelec (sum of pedelec + cyclist + load) must never be exceeded.

SAFETY

6 Proper use

Neither the manufacturer nor the specialist dealer will accept liability for damage which occurs due to improper use. Only use the pedelec in the manner described in these instructions. Any other use is considered improper and may lead to accidents, serious injury or damage to the pedelec and its components.

The warranty will be rendered void in the event of improper use of the pedelec.

Fundamentally, the following applies:

- The pedelec is designed for one cyclist.
- The sitting position on the pedelec must be correctly adjusted according to the cyclist's height.
- The maximum permitted total weight of the pedelec must not be exceeded > Chap. 11 "Maximum permitted total weight" on page 27.
- Country-specific and regional regulations must be observed to comply with the proper use of the pedelec in road traffic > Chap. 10.3 "Safety instructions for cycling in road traffic" on page 26.
- The pedelec is not approved for use with a child seat and/or trailer (child trailer, load trailer, dog trailer, etc.). Observe the instructions in the bicycle passport. > Section "Bicycle passport" on page 96.

Furthermore, the specific guidelines on proper use for the relevant classification for usage of the pedelec also apply





> Chap. 7 "Classification (classification for bicycles usage)" on page 16.

Possible examples of improper use are as follows:

- Manipulating or modifying the e-drive of an pedelec
> Chap. 8.1 "Prohibition of tuning and modifications" on page 18.
- Using an unsuitable pedelec with a child seat and/or a trailer.

7 Classification (classification for bicycles usage)

The classification corresponds to "DIN EN 17406 Classification for bicycles and EPAC usage".

Category	Description applies to cycles and EPACs	Typical range ∅ speed
	<p>used on standard paved surfaces where the tyres are intended to maintain contact with the ground at average speed, with occasional drops.</p>	<p>15 km/h to 25 km/h</p>
	<p>includes condition 1 and also unpaved roads and gravel trails with moderate gradients. In these conditions, contact with irregular terrain and repeated loss of tyre contact with the ground may occur. Drops are intended to be limited to 15 cm or less.</p>	<p>15 km/h to 25 km/h</p>
	<p>includes condition 1 and 2 as well as rough trails, rough, unpaved roads and rough terrain and unimproved roads that require technical skills. Jumps and drops are intended to be less than 60 cm.</p>	<p>Not relevant</p>
	<p>includes conditions 1, 2 and 3, or downhill gradients on rough trails at speeds of less than 40 km/h. Jumps are intended to be less than 120 cm.</p>	<p>Not relevant</p>

If you have specific questions about your model, please contact the manufacturer's Customer Service department.

Max. drop/ jump height	Intended use	Cycle type (examples)	Recommended riding skills
< 15 cm	Commuting and leisure with moderate effort	City bikes and urban bikes	No specific riding skills required
< 15 cm	Leisure and trekking with moderate effort	Trekking bike, travel bike	No specific riding skills required
< 60 cm	Sports and competitive events with moderately challenging technical trail skills	Cross-country and marathon	Requires technical skills and practice
< 120 cm	Sports and competitive events with highly challenging technical trail features	Mountain bikes, trail bikes	Requires technical skills, practice and good riding control

8 Misuse

In order to use your pedelec safely, avoid the following instances of misuse:

- Use of the pedelec for competitions, jumps, stunts or tricks if the pedelec category (classification for usage) excludes such use;
- Incorrect repairs and maintenance.
- Improper use of the Battery.
- Structural changes to the pedelec as delivered, especially to the tuning, and any other modifications to the pedelec.
- Opening and changing any components on the pedelec.
- Charging outside the temperature range specified by the manufacturer.
- Deep discharge of the battery due to long pauses in charging or improper storage of the battery outside the optimum storage temperature specified by the manufacturer.
- Ambient temperatures below +10°C and above +40°C may reduce the range.
- In the long run, especially high and especially low ambient temperatures can accelerate the wear of the battery or even damage the battery.

INFORMATION

Misuse of the pedelec can lead to the warranty becoming void.

8.1 Prohibition of tuning and modifications

Possible legal consequences:

- The pedelec is subject to registration and compulsory insurance. Any legal regulations relating to equipment and all Road Traffic Licensing Regulations apply.
- Loss of all liability, warranties and guarantees on the part of the manufacturer.
- Criminal consequences are not excluded. For example, the offence of causing negligent bodily harm could be applied.
- Loss of cover on an insured pedelec/bicycle.

Possible technical consequences:

- Changes resulting from tuning or modifications impair the function of the bike and may result in defects or component failure.
- E-drive components may become very hot and overloaded, resulting in irreparable damage or a fire hazard.
- Greater stress is placed on brakes and other pedelec components. Possible consequences may include overheating, accelerated wear, malfunctions and even total failure of the components.

9 Residual risks

Unavoidably, certain residual risks will remain when using the pedelec – despite a well-calculated design by the manufacturer and compliance with the specifications for proper use on the part of the user.

You yourself can reduce, but not completely eliminate, these residual risks by observing all safety notices and warnings. It is therefore important that you are aware that residual risks exist when using the pedelec.

The unpredictable residual risks when using the pedelec described here include:

- Unpredictable cycling manoeuvres and/or misconduct on the part of other road users;
- Distraction from the road traffic;
- Misjudging the road-holding capability and speed of the bicycle as well as your own riding skills, for example;
- Surprising or sudden changes in road characteristics such as freezing rain or black ice;
- Unexpected material defects or signs of wear that can lead to components of the pedelec breaking or being impaired in their function.

10 Safety notices

10.1 General safety information



WARNING

Risk of accident and injury!

If you do not follow the instructions listed below, which are intended to help reduce the general risk of accidents and injuries, you will expose yourself, and possibly others, to an increased risk of serious injury.

- » Only use your pedelec if you are familiar with handling it and its functions, and always follow the instructions on the proper use of your pedelec.
- » When using any approved special equipment or structures, please note that doing so may alter how you handle your pedelec and adjust your cycling style accordingly. When using recumbent or aero handlebars, access to the operating elements may be restricted, for instance, and the stopping distance may be longer than usual.
- » Ride with foresight in order to recognise events early and to be able to react to them.
- » Always adapt your cycling style and speed to the current weather conditions and road characteristics.
- » Please note in particular that the braking distance can be longer and the tyres have less grip on icy, wet, slippery or dirty roads.
- » Pay attention to other road users and adopt a defensive cycling style.
- » Always visually inspect your pedelec before using it. Make sure that your pedelec or its components do not have any cracks, scoring, damage or colour changes.
- » Make sure that safety-related devices on the pedelec (e.g. the brakes) are correctly adjusted and functional.
- » Never use your pedelec if safety-related components (e.g. the brakes) are damaged or do not function properly.
- » Under no circumstances should you arbitrarily exchange components on the pedelec or make any changes or repairs to the pedelec or individual components. Have any damage to the pedelec repaired by your specialist dealer and any damaged components replaced only with suitable original spare parts.

 **WARNING****(continued)**

- » Contact your specialist dealer if you are unable to carry out work on the pedelec described in the instructions yourself (e.g. making certain adjustments or similar tasks), if you are unsure or if you do not have the correct tools.
- » After an accident or fall or if your pedelec has been subjected to excessive loads, contact your specialist dealer for a professional inspection of your pedelec.

 **CAUTION****Risk of injury when wearing unsuitable clothing!**

Since moving parts of the pedelec are catching points for clothing, you can injure yourself if you wear unsuitable clothing when using your pedelec.

- » When cycling, wear tight-fitting legwear if possible instead of wide trousers, dresses or skirts.
- » Make sure that loose clothing cannot get caught in the moving parts of the pedelec, for example by using trouser clips.
- » Make sure that no loose straps, laces or similar are hanging down.
- » Wear shoes with non-slip soles to prevent your foot from slipping during pedalling.

NOTE**Risk of damage due to improper use!**

If the pedelec is not used in accordance with the instructions for proper use, there is a risk that components may show signs of wear or break more quickly.

- » Always observe the permitted total weight of the pedelec (including the rider and any baggage). The permitted total weight must not be exceeded.
- » Ensure that the tyre inflation pressure is set correctly and adjust it if necessary.
- » Do not cycle through deep water unless such use is explicitly permitted according to the proper use for your pedelec.

10.2 Safety instructions for the e-drive and its components

WARNING

Risk of accident and injury!

Due to its construction and design, a pedelec behaves differently in many ways to a conventional bike without an e-drive. If you underestimate this difference, you could expose yourself and others to an increased risk of serious injury.

- » Be aware of the changed cycling behaviour and do not underestimate the risks involved.
- » At the beginning, consciously practice typical cycling situations with your pedelec, such as starting and braking, cornering and turning, etc.
- » Find out about any applicable national regulations for pedelec and observe them.

WARNING

Risk of electric shock and injury!

Improper handling of the pedelec or e-drive may result in an electric shock and/or serious injury.

- » Always remove the battery from its holder on the pedelec before carrying out any work, before transporting it or storing it for a longer period of time in order to prevent you or others from accidentally starting the e-drive.
- » Do not make any changes or modifications to the e-drive. Never try to increase the power of the e-drive!
- » Do not modify or exchange components of the e-drive yourself under any circumstances.
- » Do not open the components of the e-drive yourself under any circumstances. The components of the e-drive are maintenance-free. Have any necessary repairs to the e-drive carried out exclusively by an authorised specialist dealer.
- » Only have components of the e-drive replaced with approved original spare parts by an authorised specialist dealer.
- » Only use the "Walk Assistance" function when pushing your pedelec: When the Walk Assistance function is activated, the pedelec should be held securely with both hands and the wheels should be in contact with the ground, otherwise there is a risk of injury. Do not use the Walk Assistance function to propel you forward while sitting on the pedelec.

**WARNING****Risk of electric shock!**

Improper handling of electrical power and live components may result in an electric shock.

- » Check the charger, mains cable and mains plug for damage before each use. Do not use the charger if you discover damage or suspect that it is damaged.
- » If the charger's power cable is damaged, it must be replaced by the manufacturer, its Customer Service department or a similarly qualified person in order to avoid hazards.
- » Do not kink the charger's power cable or place it over sharp edges.
- » Only connect the charger to a properly installed and easily accessible power outlet with a mains voltage that matches the voltage indicated on the charger.
- » Only use the charger in dry, indoor rooms.
- » Make sure that the mains voltage at the mains connection corresponds to the specification on the charger.
- » Do not allow the charger and the battery or the connection contacts for the battery on the pedelec to come into contact with water or other liquids.
- » Keep the components of the e-drive (especially the connection contacts on the battery and charger) in a clean condition.
- » Do not pull on the power cord or charger cable to remove the respective cable from a socket or outlet, instead, always take hold of the respective plug.
- » Never touch the plugs of the power cable or charger cable with wet or damp hands.

**WARNING****Risk of explosion!**

If a battery is not handled properly, it can explode.

- » Keep the battery away from fire and other heat sources.

 **WARNING****Fire hazard!**

Improper handling of the battery and charger may cause a fire.

- » Only use the charger in dry, indoor rooms under supervision.
- » The battery and charger may heat up during charging: keep flammable materials away from the battery and charger, and place the charger on a fireproof surface when charging the battery.
- » Only use the original charger to charge the battery.
- » Only use the charger to charge the original battery. Do not charge other batteries with it.
- » Always pull the mains plug out of the socket after charging.
- » Observe any additional safety instructions on the charger.
- » Do not store the battery near metal objects such as coins, paper clips, screws, etc. Metal objects can "short-circuit" the battery. The short circuit may cause a fire.
- » Do not short-circuit the battery.

 **WARNING****Risk of chemical burns and injury!**

Improper handling of the battery can cause burns and/or injuries to you and others.

- » Have the battery checked by an authorised specialist dealer after a fall or hard impact to ensure that there is no (invisible) damage that could allow battery acid or toxic gases to escape.
- » Do not open, dismantle, drill through or deform the battery or battery housing.
- » Only touch a damaged battery when wearing protective gloves.
- » In case of contact with damaged batteries, wear safety glasses and protective clothing to avoid contact with battery acid.
- » In case of contact with battery acid, immediately rinse the affected area thoroughly under plenty of running water. Consult a doctor after rinsing, especially in the event of eye contact and/or if mucous membranes (e.g. nasal mucous membranes) are affected.
- » If the battery has caught fire, proceed as follows: Immediately remove yourself from the burning battery, shield the scene of the fire as much as possible, and call the fire service. Do not try to extinguish the burning battery yourself with water!



WARNING

Hazards for certain groups of persons (e.g. children)!

Children or persons who are physically or mentally impaired may be seriously injured when handling the battery and/or charger or when accessing your pedelec as they may not be able to correctly assess certain risks.

- » The charger must not be used by children or persons with impaired physical, sensory or mental abilities unless they are supervised or have been instructed in the safe use of the charger and have understood the resulting risks.
- » Children must not play with the battery or the charger.
- » Cleaning and user maintenance must not be carried out by children without supervision.
- » The battery must not be removed or inserted by children.
- » Keep the battery and charger out of the reach of children.
- » Secure and park your pedelec so that unauthorised persons (especially children) cannot access it.



CAUTION

Risk of burns!

The motor unit heats up during operation. Touching the hot engine unit may cause burns.

- » Be careful when handling the motor unit.
- » Let the motor unit cool down completely before touching it.

NOTE

Risk of damage!

Improper handling can damage the e-drive or its components.

- » Have all components of the e-drive and pedelec replaced exclusively with identical or other components, expressly approved by the manufacturer, to prevent damage to other components or to the pedelec.

10.3 Safety instructions for cycling in road traffic

WARNING

Risk of accident and injury!

If you do not follow the instructions listed below, which are intended to help reduce the general risk of accidents and injuries, you expose yourself, and possibly other persons, to an increased risk of injury.

- » Before using your pedelec in road traffic, make sure that it complies with the country-specific regulations. For use in road traffic, pedelecs must always be fitted with two independent brakes and a bell.
- » Observe and respect all national and regional road traffic regulations. For information on the applicable road traffic regulations in the country or region, contact the Ministry of Transport, for example.
- » When cycling, wear a suitable bicycle helmet tested in accordance with DIN EN 1078 (with the CE mark of conformity).
- » Wear bright colours when cycling and make sure that you are easy to notice by wearing reflective clothing.
- » Do not use your pedelec if you have consumed alcohol, intoxicants or debilitating drugs.
- » Do not use mobile devices such as smartphones or tablets while cycling.
- » Remain concentrated while cycling. Do not allow yourself to be distracted by actions such as switching on the light. You should stop to carry out such actions.
- » Never cycle one-handed or with no-hands in road traffic.
- » Cycle on the prescribed cycle paths.

11 Maximum permitted total weight



WARNING

Risk of accident and injury!

Overloading the pedelec can cause safety-related components to break or fail, resulting in accidents and injuries.

» Never exceed the maximum permissible total weight of the pedelec.

NOTE

Risk of damage!

Overloading the pedelec can lead to material damage.

» Never exceed the maximum permissible total weight of the pedelec.

The pedelec has a maximum permitted total weight that must be observed when using the pedelec.

You can find the maximum permissible total weight on the product marking of your pedelec > Chap. 5 "Product marking" on page 14 and in the bicycle passport > Section "Bicycle passport" on page 96.

The maximum permitted total weight is calculated from the sum of the following weight specifications:

Pedelec + cyclist + baggage = maximum permitted total weight.

12 Torques

WARNING

Risk of accident and injury!

Incorrectly tightened screw connections can result in material fatigue and eventually cause the screw connections to break.

- » Do not use your pedelec if you notice any loose screw connections.
- » Screw connections must be properly tightened with a torque spanner and the correct torque.

Observe the relevant torque to ensure the screw connections are tightened correctly. A torque spanner with a suitable adjustment range is required for this task.

The correct torque for a screw connection depends on the material and diameter of the screw connection, as well as the material and design of the component.

- If you do not have any experience with using torque spanners or if you do not own a suitable torque spanner, you should ask your specialist dealer to check your screw connections for you.
- If you decide to tighten the screw connections yourself, check whether your pedelec is fitted with aluminium or carbon components.
- Observe the specific torques for components manufactured from carbon.

12.1 Overview of tightening torques

The following tables lists the torque specifications for add-on parts. Ask your specialist dealer for any torque specifications that are not listed.

INFORMATION

If the torques specified on the components deviate from the specifications in the table, the torques on the components take priority.

General tightening torques

Screw connection	Torque in Nm
Pedals	35 Nm
Adjustable fork end (PRISMA, FUTOUR, ORAMA)	6-7.5 Nm
Grips (bolted)	2 Nm
Brake lever with plastic clamp	6 Nm
Brake lever with aluminium clamp	8 Nm
Headlight (M6 screw, also for securing the mudguard)	8 Nm
Carrier fixing screws	8 Nm

IDEAL MY 2022

Recommended tightening torques

MODEL	MODEL ID	HANDLEBAR-HANDLESTEM	HANDLESTEM-FORK STEERER
HILLMASTER-609 GTS_622 mtb	4029642 (M)	5 Nm	8 Nm
PRISMA-810X sport_622 sport	4029592 (M)	6-8 Nm	10-12 Nm
PRISMA-810FX WAV_584 trekking	4027522 (W)	6-8 Nm	10-12 Nm
PRISMA-810FX WAV_622 trekking	4029582 (W)	6-8 Nm	10-12 Nm
PRISMA-810FX GTS_622 trekking	4029572 (M)	6-8 Nm	10-12 Nm
PRISMA-810X WAV_584 trekking	4027512 (W)	6-8 Nm	10-12 Nm
PRISMA-810X WAV_622 trekking	4029562 (W)	6-8 Nm	10-12 Nm
PRISMA-610X WAV_584 trekking	4027502 (W)	6-8 Nm	10-12 Nm
PRISMA-610X WAV_622 trekking	4029552 (W)	6-8 Nm	10-12 Nm
PRISMA-610X LDS_622 trekking	4029542 (L)	6-8 Nm	10-12 Nm
PRISMA-610X GTS_622 trekking	4029532 (M)	6-8 Nm	10-12 Nm
PRISMA-610 WAV_584 trekking	4027612 (W)	6-8 Nm	10-12 Nm
PRISMA-610 GTS_622 trekking	4029632 (M)	6-8 Nm	10-12 Nm
PRISMA-609 WAV_584 sport+	4027602 (W)	6-8 Nm	10-12 Nm
PRISMA-609 WAV_622 sport+	4029622 (W)	6-8 Nm	10-12 Nm
FUTOUR-810X WAV_622 trekking	4028372 (W)	6-8 Nm	10-12 Nm
FUTOUR-810X LDS_622 trekking	4028362 (L)	6-8 Nm	10-12 Nm
FUTOUR-810X GTS_622 trekking	4028352 (M)	6-8 Nm	10-12 Nm
FUTOUR-610FX WAV_622 trekking	4028342 (W)	6-8 Nm	10-12 Nm
FUTOUR-610FX GTS_622 trekking	4028332 (M)	6-8 Nm	10-12 Nm
FUTOUR-610X WAV_622 trekking	4028322 (W)	6-8 Nm	10-12 Nm
FUTOUR-610X LDS_622 trekking	4028312 (L)	6-8 Nm	10-12 Nm
FUTOUR-610 WAV_622 trekking	4028412 (W)	6-8 Nm	10-12 Nm
FUTOUR-610 GTS_622 trekking	4028402 (M)	6-8 Nm	10-12 Nm
FUTOUR-609 WAV_622 trekking	4028302 (W)	6-8 Nm	10-12 Nm
FUTOUR-509 WAV_622 trekking	4028392 (W)	5 Nm	8 Nm
FUTOUR-508 WAV_622 trekking	4028382 (W)	5 Nm	8 Nm
ORAMA-605DX WAV_622 city	4028222 (W)	6-8 Nm	10-12 Nm
ORAMA-605N WAV_622 city	4028212 (W)	6-8 Nm	10-12 Nm
ORAMA-605C WAV_622 city	4028202 (W)	6-8 Nm	10-12 Nm

	ADJUSTABLE HANDLESTEM	SADDLE-SEAT POST	SEAT CLAMP	FRONT HUB	REAR HUB	REAR DERAILLEUR HANGER
	n/a	12 Nm	QR	QR	QR	10 Nm
	n/a	10-12 Nm	QR	QR	QR	10 Nm
	n/a	10-12 Nm	QR	QR	QR	n/a
	n/a	10-12 Nm	QR	QR	QR	n/a
	n/a	10-12 Nm	QR	QR	QR	n/a
	n/a	10-12 Nm	QR	QR	QR	n/a
	n/a	10-12 Nm	QR	QR	QR	n/a
	n/a	10-12 Nm	QR	QR	QR	n/a
	n/a	10-12 Nm	QR	QR	QR	n/a
	n/a	10-12 Nm	QR	QR	QR	n/a
	n/a	10-12 Nm	QR	QR	QR	10 Nm
	n/a	10-12 Nm	QR	QR	QR	n/a
	n/a	10-12 Nm	QR	QR	QR	10 Nm
	n/a	10-12 Nm	QR	QR	QR	n/a
	n/a	10-12 Nm	QR	QR	QR	n/a
	17-18,5 Nm	10-12 Nm	QR	QR	QR	n/a
	17-18,5 Nm	10-12 Nm	QR	QR	QR	n/a
	17-18,5 Nm	10-12 Nm	QR	QR	QR	n/a
	17-18,5 Nm	10-12 Nm	QR	QR	QR	n/a
	17-18,5 Nm	10-12 Nm	QR	QR	QR	n/a
	17-18,5 Nm	10-12 Nm	QR	QR	QR	n/a
	17-18,5 Nm	10-12 Nm	QR	QR	QR	n/a
	17-18,5 Nm	10-12 Nm	QR	QR	QR	n/a
	17-18,5 Nm	10-12 Nm	QR	QR	QR	n/a
	17-18,5 Nm	10-12 Nm	QR	QR	QR	n/a
	15 Nm	10 Nm	QR	QR	QR	n/a
	15 Nm	10 Nm	QR	QR	QR	10 Nm
	17-18,5 Nm	10-12 Nm	QR	QR	30-45 Nm	n/a
	17-18,5 Nm	10-12 Nm	QR	QR	30-45 Nm	n/a
	17-18,5 Nm	10-12 Nm	QR	QR	30-45 Nm	n/a

13 Maintenance and wear

WARNING

Risk of accident and injury!

Incorrect or unauthorised assembly and maintenance work can damage the pedecec or its components.

- » Do not overestimate your technical abilities. Only have assembly and maintenance work carried out by an authorised specialist dealer, especially the replacement of components and spare parts.
- » Never work on or modify the pedecec or its components if you do not have the necessary expertise and tools.

13.1 Wear

WARNING

Risk of accident and injury!

Excessive wear, material fatigue or loose screw connections can cause functional impairments and may lead to accidents or falls.

- » Check your pedecec regularly for wear.
- » Do not use your pedecec if you notice any cracks, deformations or changes in colour.
- » Do not use your pedecec if you notice excessive wear or loose screw connections.
- » Have your pedecec checked immediately by your specialist dealer if you notice excessive wear, loose screw connections, cracks, deformations or colour changes.

The pedecec and its components are subject to wear and high mechanical stress. The materials used have different wear properties based on their composition.

Only your specialist dealer is qualified to assess wear on components.

- Ask your specialist dealer for advice on components that are subject to wear.
- Check the condition of all wear parts at regular intervals.
- Clean and maintain wear parts regularly.

13.2 Replacing components

WARNING

Risk of accident and injury!

Replacing components or incorrectly selected replacement parts may prevent the pedelec from functioning correctly.

- » Only have components replaced by your authorised specialist dealer.
- » Only have components or spare parts replaced with original parts.

14 Notes on components made of carbon

WARNING

Risk of accident and injury!

Material failure due to non-visible cracks or deformations caused by a fall or overloading.

- » Do not use your pedelec if you suspect damage.
- » Have carbon components checked by your specialist dealer after overloading or a fall, even if they show no visible signs of damage.
- » Have carbon components checked by your specialist dealer at regular intervals, even if they have not been subjected to overloading.

NOTE

Risk of damage!

Material damage or increased wear due to incorrect care of carbon components.

- » Avoid contact of carbon components with grease and oil.

Hard impacts, shocks and tension can damage components such as frames, forks, handlebars and wheels made of carbon. This has a detrimental effect on the internal structure of the material without this damage being outwardly visible.

- Have carbon components checked by a specialist dealer at regular intervals.

BEFORE FIRST USE

Your specialist dealer has fully assembled the pedelec, made all the necessary adjustments based on your height and weight, and explained to you how to operate and use the components.

Your pedelec is thus ready to use.

15 Familiarise yourself with the pedelec

- Practice riding your new pedelec away from road traffic before embarking on longer rides with your pedelec and/or riding on the road.
 - Familiarise yourself with the riding characteristics of your pedelec.
 - Try the brakes by braking at a low speed initially. Once you feel confident doing this, increase the speed and try different braking manoeuvres.
 - Shift through the different gears and familiarise yourself with the riding characteristics of the pedelec in each gear. You should be able to shift gears in such a way that it does not distract your attention from road traffic.
 - Make sure that the adjusted sitting position is also comfortable for longer distances and that you are able to operate the brake lever and operating elements on the handlebar safely and easily while riding.
- Bed-in the disc brakes, if necessary
> Chap. 25.4 "Bedding in disc brakes" on page 54.
- If you wish to change the preset position of the brake levers for the front wheel or rear wheel brake, have them repositioned by your specialist dealer.

16 Check your pedelec before you start riding.

Perform the checks described here before every ride.

- Before setting off, check that the components listed below are working properly and are undamaged.
- Contact your specialist dealer to have the components replaced if you notice that:
 - the function of the components is impaired,
 - the component is damaged,
 - the component shows signs of excessive wear.

Brakes:

- Check the front and rear wheels, one after the other, to ensure that they lock securely when you pull on the respective brake lever.

Gear shift system:

- Lift the rear part of the pedelec so that you can move the rear wheel and turn the pedals to set the rear wheel gently in motion.
- Shift through all the gears: shifting should be easy; there should be no blockages or unusual noises.

Frame, fork and seat post:

- Check the components for damage and signs of wear such as cracks, deformations or changes in colour (visual inspection).

Quick-release devices:

- Check that the quick-release clamps are securely fastened and closed.
- Check that the initial tension of the quick-release clamps is sufficient.

Screw and plug connections

- Check that the screw and plug connections are securely fastened and closed (visual inspection).

Pedal drive:

- Lift the rear part of the pedelec so that you can move the rear wheel, and use the pedals to set the rear wheel gently in motion.
- Check that the pedal drive is working properly and securely fastened.

Handlebar and handlebar stem:

- Check that the handlebar and handlebar stem are securely mounted in their respective attachments and cannot move.
- Check the components for damage and signs of wear such as cracks, deformations or changes in colour (visual inspection).

Tyres:

- Check whether the tyre pressure is sufficient.
- Check whether there are any cracks or foreign objects on the tyres.
- Check the rims for damage and signs of wear such as cracks or deformations (visual inspection).
- Check that the spokes are evenly tensioned.

Bell:

- Check that the bell works. It should make a clear sound.

Lights:

- Check the headlight and rear light to ensure that they work correctly.

E-drive:

- Check the battery and drive for any damage (visual inspection).
- Check that the battery is mounted correctly and that the battery lock is locked.
- Check the charge level of the battery.

17 Setting the optimum sitting position

⚠ CAUTION

Risk of injury!

An incorrect sitting position can cause muscle tension and joint pain. If you have difficulty accessing the operating elements on the handlebar due to an incorrectly set sitting position, the risk of accidents increases.

» If you are unsure, ask your specialist dealer to adjust the sitting position correctly.

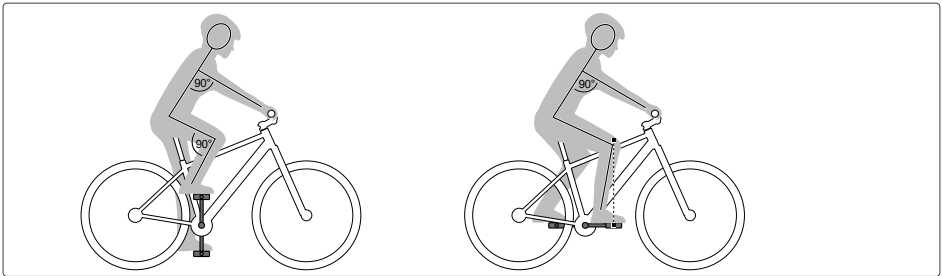

Fig. 2: Guide to the optimum sitting position

Various factors can influence the optimum sitting position, e.g.:

- the height of the cyclist,
- the frame size and geometry of the pedelec,
- the saddle and handlebar positions,
- the conditions of use where applicable (e.g. predominantly used for sports activities).

Guidance for setting the optimum sitting position include:

- Arm and knee (upper leg) angles are 90° when one pedal is up. Your lower leg is slightly bent.
- Your knee is above the axle of the front pedal when one pedal is in front.
- Your arms are relaxed and slightly bent outwards.
- Your back is not vertical in relation to the seat post.

Adjust the saddle and handlebar until you achieve the optimum sitting position to suit your requirements

- > Chap. 34 "Adjusting the saddle" on page 69 and
- > Chap. 35 "Adjusting the handlebar" on page 72.

PEDAL DRIVE

18 General information

The term "pedal drive" refers to the process or related unit with which the pedelec is (manually) propelled.

The power applied when you push the pedals (pedalling) is transmitted to one of the wheels via the chain (chain drive). In turn, the propelled wheel sets the entire pedelec in motion.

INFORMATION

It is generally the rear wheel that is propelled in this way.

19 Chain drive

19.1 Method of operation and handling

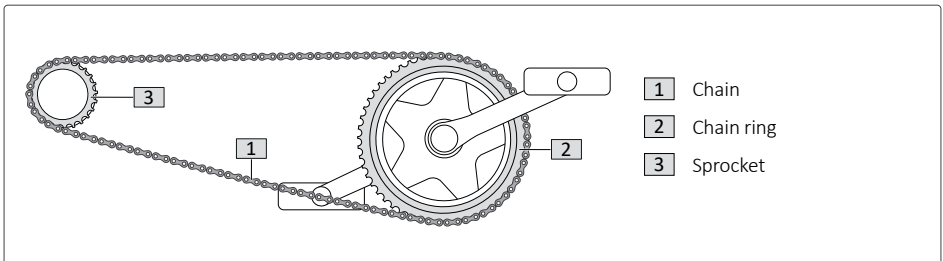

Fig. 3: Chain drive components

The chain of the pedelec runs over two gear wheels, the teeth of which interlock with the free openings between the individual chain links that make up the chain.

The gear wheel at the same level as the pedals that rotates when you start to pedal is known as a chain ring. The rotation of the chain ring is transmitted to the sprocket on the wheel axle via the chain. The rotating sprocket also causes the wheel to rotate, which propels the entire pedelec and sets it in motion.

INFORMATION

In principle, it is possible to open a chain and to close it again. Individual chain links can be inserted or removed to achieve the perfect chain length.

19.2 Wear and maintenance

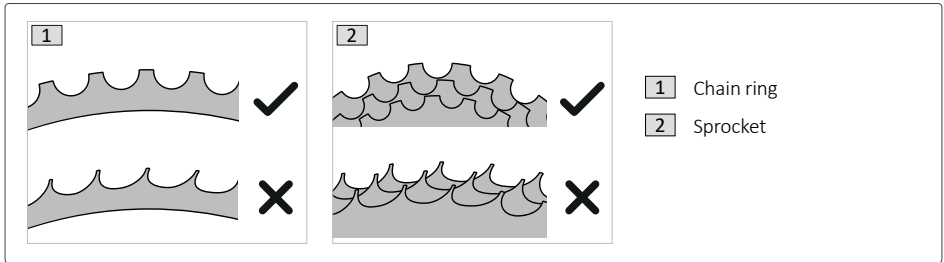

Fig. 4: Possible signs of wear on chain drive components

Chain ring and sprocket

If the teeth on the chain ring and/or sprocket are worn due to material abrasion, movement of the chain over the corresponding gear wheel is not as reliable and it can easily slip off.

Chain and chain links

If the chain links are worn due to material abrasion, the free openings between them, that interlock with the teeth, widen. As a result, movement of the chain over the corresponding gear wheel is not as reliable and it can easily slip off. You may also have the impression that the chain has stretched.

Check the chain rings, sprockets and chain regularly for signs of wear.

- Contact your specialist dealer to have worn chain rings or sprockets replaced.
- If you have the impression that the chain has stretched or you notice signs of wear on the chain links, contact your specialist dealer to have the chain adjusted correctly or replaced.

19.3 Cleaning and care

Keep all chain drive components free of dirt and clean the components regularly to ensure your chain drive continues to function correctly.

- Clean the chain using a clean cloth with a dab of oil applied, if required.
- If necessary, clean the gear wheels with a soft brush.
- Lubricate the chain with multi-purpose oil:
 - after you have cleaned the chain,
 - if the chain has become (excessively) wet,
 - at regular intervals, after approximately 15 hours of use.
- If the dirt on certain chain drive components is more difficult to remove or you notice that the chain drive components are damaged, contact your specialist dealer.

SPECIAL CHARACTERISTICS OF THE E-DRIVE

i INFORMATION

This section provides information that you must observe when using a pedelec as opposed to a conventional bike.

The separate manufacturer's instructions accompanying the e-drive contain detailed descriptions relating to the specific model of e-drive and its components, including all relevant details as well as safety notices and warnings.

- Always observe the separate manufacturer's instructions accompanying the e-drive in addition to these pedelec instructions.

20 General/components

Fig. 5: E-drive components on the pedelec

Unlike conventional bikes, pedelecs are fitted with an electrical auxiliary motor that helps the cyclist propel the pedelec forwards or relieves the cyclist when pedalling.

These instructions contain a list of e-drive components used to provide electric motor assistance, including:

- the electrical auxiliary motor (as a motor unit),
- the battery (for supplying energy to the electrical auxiliary motor),
- the charger (for charging the battery),
- the control unit (for operating/controlling the e-drive),
- the display (for displaying riding parameters, available settings, etc.).

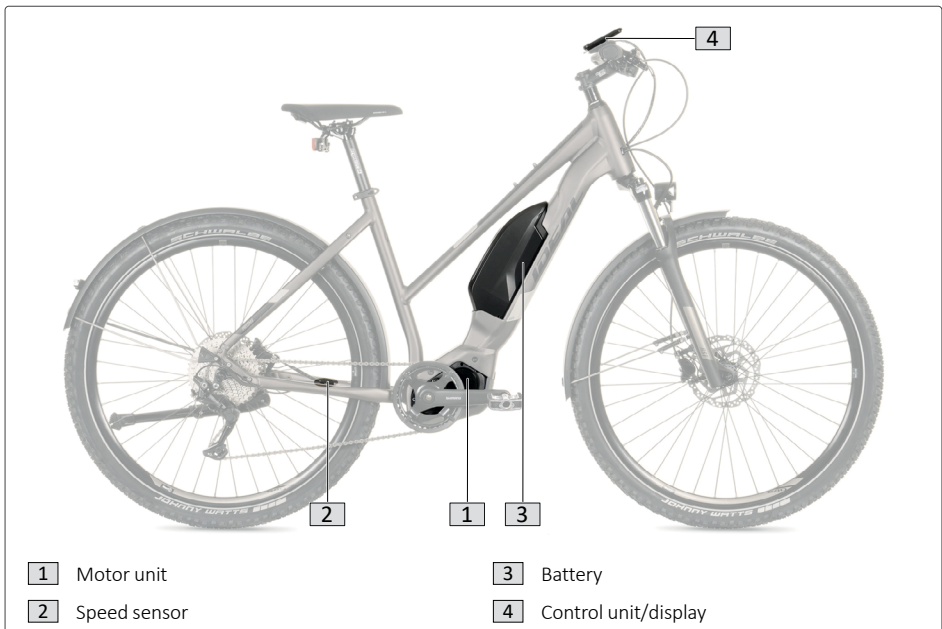
Due to the additional components of the e-drive, a pedelec is fundamentally different to a conventional bike without an e-drive in several ways.

- The much higher weight and different weight distribution of a pedelec have an impact on riding performance.
 - The e-drive has a significant influence on braking performance.
 - The brake components on a pedelec can wear out more quickly due to the higher braking power.
 - You are likely to ride at a higher average speed on a pedelec and can take on more challenging routes.
- Always familiarise yourself with your pedelec before riding for the first time.
 - Never underestimate the fundamental differences between a bike without an e-drive and a pedelec, especially if you have no previous experience with pedelecs > Chap. 15 "Familiarise yourself with the pedelec" on page 34.

21 Information on use

INFORMATION

The separate manufacturer's instructions accompanying the e-drive include detailed descriptions of the operating steps required to use the e-drive.

The instructions include information on:

- operating the e-drive
- (e.g. how to switch the e-drive on and off, set/change the pedal assistance level, adjust settings, etc.),
- handling batteries,
- (e.g. how to insert/remove the battery from the pedelec, charge the battery, information on charging times, protective equipment, etc.)
- indicators that appear on the display and/or operating element(s),
- warning and indicator lights (e.g. on battery, display).

21.1 Method of operation

When the e-drive on your pedelec is switched on, the electric auxiliary motor provides assistance while you are riding the pedelec. At speeds of 25 km/h and above, the electrical pedal assistance switches off, leaving you to pedal with your own muscle power without the assistance of the motor. The speed is measured by the speed sensor and spoke magnet on the rear wheel.

The level of pedal assistance from the motor depends on how hard you are pedalling yourself. When you are not pedalling, the e-drive will not provide any assistance unless the "Pushing Aid" function is activated. When you activate the Pushing Aid function, the motor helps you push the pedelec up to speeds of 6 km/h. The Pushing Aid function may not be used to propel the pedelec when a cyclist is sitting on the pedelec, but only to push it. Your pedelec must be held securely with both hands and the wheels must be in contact with the ground.

21.2 Removing and inserting the battery

CAUTION

Risk of burns!

The motor and battery can become extremely hot during operation.

» Always allow the components to cool down before handling them or putting your hands near them.

NOTE

Risk of damage!

You can damage the battery if you remove it while the e-bike system is switched on.

» Always switch off the e-bike system before removing the battery.

21.2.1 Removing and inserting the fully integrated battery

Removing the battery cover

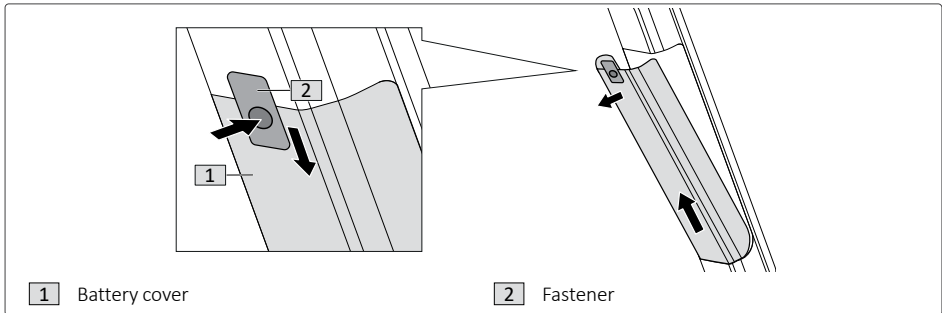

Fig. 6: Removing the battery cover

1. Unlock the battery cover **1**.
To do this, press and hold the button on the battery cover lock **2** and slide the lock towards the motor unit.
The upper part of the battery cover is now unlocked.
2. Pull the battery cover out of the lower holder and remove the battery cover.

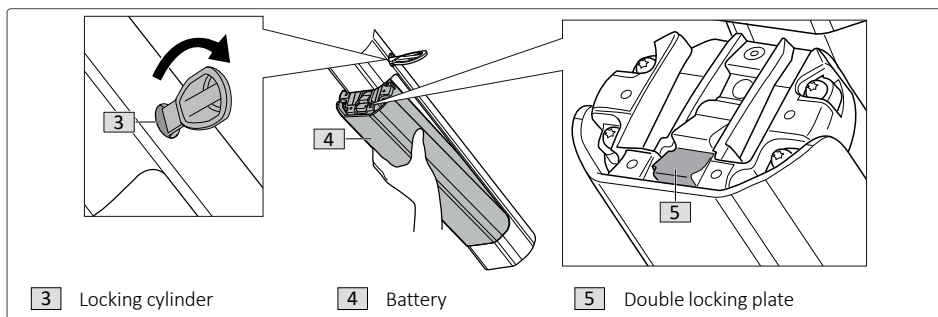

Fig. 7: Removing/inserting the fully integrated battery

Removing the fully integrated battery

1. Switch off the e-bike system and battery.
2. Insert the key into the locking cylinder **3** of the battery holder.
3. Support the battery **4** with one hand and turn the key clockwise to unlock the battery. The double locking plate **5** holds the battery in the intended position to prevent it from falling out. If the battery is not released from its position, pull it out by hand while turning the key.
4. Hold the battery firmly in one hand and press the double locking plate **5**. The battery is unlocked and can be removed from the holder in the direction of the head tube.

Inserting the fully integrated battery

1. Insert the battery into the frame with the contacts on the lower battery holder.
2. Push the battery into the upper holder as far as it will go until you feel it click into place.
3. After insertion, check that the battery is firmly and securely engaged by carefully pulling it.

Mounting the battery cover

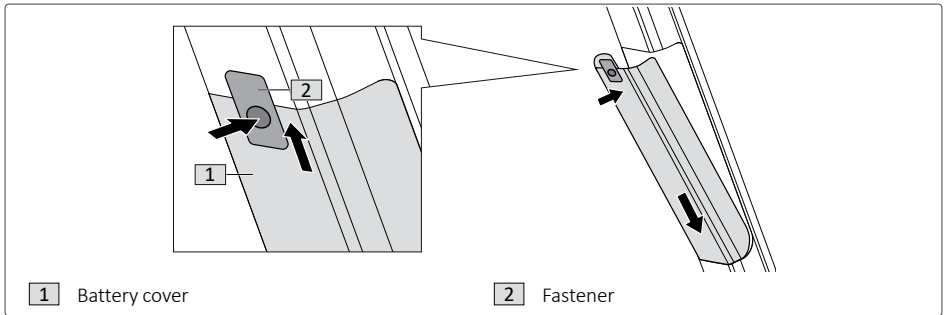

Fig. 8: Mounting the battery cover

1. Insert the battery cover **1** into the lower holder of the frame.
2. Push the battery cover into the upper holder as far as it will go, press and hold the button on lock **2** of the battery cover and slide the lock towards the head tube. The upper part of the battery cover is now locked.
3. After insertion, check that the battery cover is firmly and securely seated in the holder and locked in place by carefully pulling it.

21.2.2 Removing and inserting the semi-integrated battery

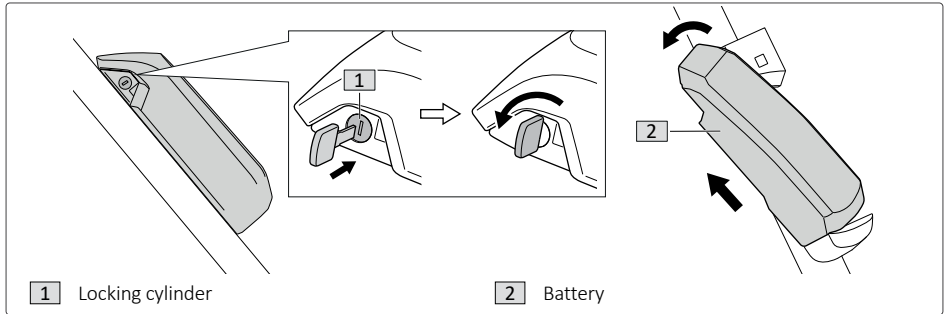

Fig. 9: Removing/inserting the semi-integrated battery

Removing the battery

1. Switch off the e-bike system and battery.
2. Insert the key into the locking cylinder **1** of the battery holder.
3. Hold the battery **2** securely with one hand and turn the key in an anti-clockwise direction to unlock the battery.
4. First tilt the battery to the side and then pull it up and out of the holder.

Inserting the battery

The battery can also be inserted when the lock is engaged.

1. Guide the battery **2** towards the lower battery holder from above and align the recess on the underside of the battery with the catch on the battery holder.
2. Swivel the battery to the right until you feel it click into place.
3. After insertion, check that the battery is firmly and securely engaged by carefully pulling it.

21.3 Riding without the e-drive

You can easily use your pedelec as a conventional bicycle without the e-drive, for example, if the battery charge is completely used up during a longer ride, if you deliberately switch off the e-drive or if you select the support level "none".

If you use your pedelec without the battery inserted, make sure that the battery holder or the connection contacts in the holder are protected from dirt and damage, e.g. using a suitable cover.

21.4 Range/route planning

Several factors determine how long or far you can ride your pedelec before the battery charge gets completely used up, including:

- which support level is set.
 - the speed at which you are riding the pedelec.
 - your riding style.
 - the tyre type and current tyre pressure.
 - the surface conditions along the selected route.
 - the weather conditions.
 - the total weight of the pedelec, cyclist and baggage.
 - the condition and age of the battery.
- Gradually familiarise yourself with your pedelec away from any roads and heavy traffic.
 - Test the maximum range of your pedelec under a variety of external conditions and make careful calculations before planning longer trips. You cannot precisely determine the exact range of your pedelec either before or during a trip.

21.5 Storage and operating temperatures

- When storing your pedelec, observe the operating and storage temperatures of the e-drive components. Do not store your pedelec in direct sunlight with the battery inserted, as extreme temperatures may damage the battery and even cause it to explode.

21.6 Cleaning and care

WARNING

Risk of electric shock and short circuit!

There is a risk of electric shock and short circuiting during cleaning and maintenance work. Water can penetrate into the electrical system or drive and damage the pedelec.

- » Pull the charger's mains plug out of the socket.
- » Remove the battery.
- » Do not clean e-drive components with running water or other liquids.
- » Do not use a steam cleaner, high-pressure cleaner or water jet.
- » Do not allow the charger and the battery or the connection contacts for the battery on the pedelec to come into contact with water or other liquids.

CAUTION

Risk of burns!

The motor and battery can become extremely hot during operation.

- » Always allow the components to cool down before handling them or putting your hands near them.

Keep any e-drive components free of dirt or clean the components regularly.

- Clean any soiled components with a damp cloth.
- Use a mild cleaner.
- Prevent moisture or dirt from contaminating the contacts.

BRAKES

22 General information

The pedelec is fitted with at least two brakes that act on the front wheel (front wheel brake) and rear wheel (rear wheel brake) independently of one another.

You can use the brakes to slow down or stop the pedelec. Each of the brakes slows down the corresponding wheel, which in turn decelerates the entire pedelec.

The brakes for each wheel are operated using the corresponding brake lever, mounted on the handlebar.

23 Brake lever configuration

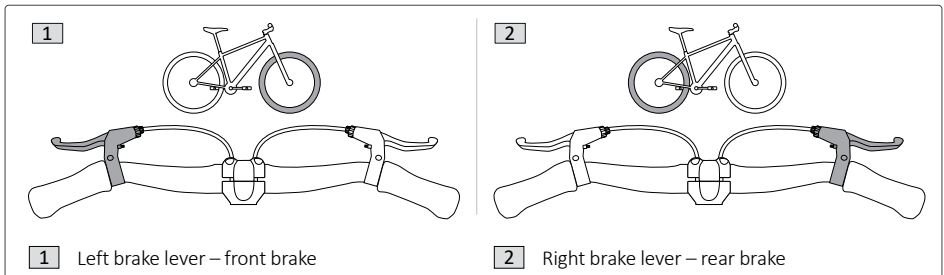

Fig. 10: Brake lever assignment

The brake lever configuration shown here applies to pedelecs with two brake levers mounted on the handlebar.

- Familiarise yourself with the brake lever configuration before starting to cycle.
- Consult your specialist dealer if you wish to change the brake lever configuration.

24 Warnings for using the brakes

The following warnings always apply to the use of brakes, regardless of the type or types of brakes fitted to the pedelec.

WARNING

Risk of accident and injury!

When you ride on icy, wet, slippery or dirty roads, the tyres have less grip. This lack of grip reduces the braking power, increases the braking distance and the pedelec can swing out if you brake suddenly.

» Always adapt your cycling style and speed to the current weather conditions and road characteristics.

WARNING

Risk of accident and injury!

If you brake the front wheel abruptly, you could be thrown over the handlebar or fall off the pedelec.

- » Use the front brake very cautiously when riding at high speed.
- » Always brake simultaneously with the front and rear brakes. Make sure that you do not brake your pedelec abruptly with only the front brake, especially when riding at high speed.
- » Adjust the intensity with which you brake your pedelec – i.e. the braking power – according to the cycling situation.

WARNING

Risk of accident and injury!

If you brake the rear wheel abruptly during certain cycling manoeuvres, the wheel may block, causing you to fall.

» Be very careful when using the rear brake around corners.



WARNING

Risk of accident and injury!

If the pedelec is fitted with unsuitable or incorrect brake pads, the braking power may be too low or too strong, and the brake can virtually lose its function entirely and fail completely.

- » Always have any brake components replaced (e.g. when carrying out repairs) with original spare parts only.



WARNING

Risk of accident and injury!

If your pedelec is fitted with a power modulator, this modulator alters the braking power of the front brake. If the power modulator is set incorrectly or you have never braked using the power modulator before, the risk of losing your control and/or falling while braking will be much greater.

- » Familiarise yourself with the function and operation of the brake and power modulator away from road traffic.

25 Disc brake

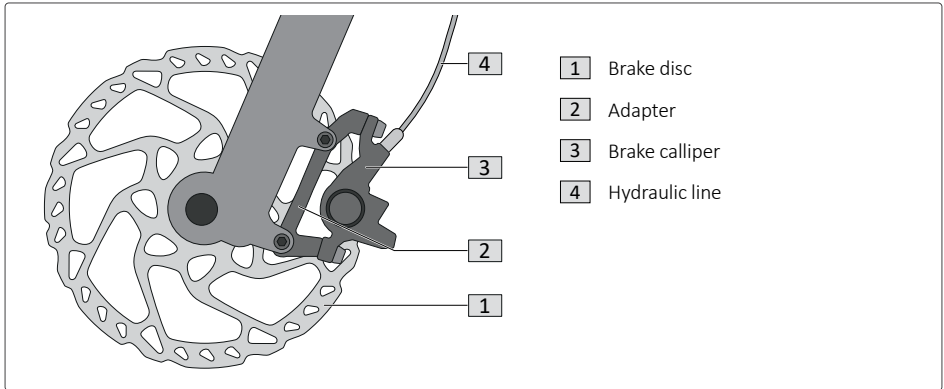

Fig. 11: Disc brake components

25.1 Method of operation

The disc brake creates a braking effect when the brake lever is pulled to decelerate the brake disc.

The brake disc is decelerated by the brake calliper attached to the fork or chainstay. The brake calliper contains brake pads that are pressed against both sides of the brake disc when the brake lever is pulled.

The force is usually transferred hydraulically. Pulling the brake lever increases the pressure on the brake fluid in the hydraulic line. The brake fluid transfers this pressure to the brake calliper and presses the brake pads against the brake disc, thereby braking the wheel.

Depending on the model, the braking power can also be transmitted mechanically from the brake lever to the hydraulically-controlled brake calliper along a brake cable.

25.2 Warnings relating to the use of disc brakes

WARNING

Risk of accident and injury!

If components of the disc brake wear out without you noticing it, a loss of function of the disc brake can result.

- » Contact your specialist dealer regularly (annually, after 100 hours of use or after 1,000 km) to have your disc brake(s) checked and any worn components replaced.

WARNING

Risk of injury from rotating brake discs and sharp edges!

Brake discs have sharp edges and can cause serious cuts. Rotating brake discs can sever limbs.

- » Do not reach into a rotating brake disc.
- » Wear protective gloves when working on or near the brake disc.

WARNING

Risk of accident and injury!

The braking power of the hydraulic braking system decreases.

- » Have the brake fluid replaced regularly by your specialist dealer.

CAUTION

Risk of burns from contact with hot brake discs!

Brake discs can become very hot due to solar radiation and when in use, especially when the brake is used intensively (e.g. when cycling downhill or during emergency braking).

- » Always let the brake disc cool down first before working on or near the brake disc.

NOTE**Risk of damage!**

Depending on the intensity of use, the brake pads on the disc brake can "glaze over" as time goes by, possibly reducing the braking effect and generating disturbing noises (squeaking). Glazing-over can also occur when you make an emergency stop with new brake pads. You may also damage the disc brake components when fitting or removing the corresponding wheel.

- » When going down hill for longer distances, regularly perform abrupt, relatively hard braking actions to "release" the glazed-over brake pads. Always make sure that you can perform the cycling or braking manoeuvre in question without risk.
- » If the disc brake and/or your pedelec is new or after the brake pads have been replaced, bed-in the disc brake away from road traffic before using your pedelec regularly > Chap. 25.4 "Bedding in disc brakes" on page 54.
- » Always contact your specialist dealer to have them remove or install a wheel with a disc brake fitted to its hub.

25.3 Operating the disc brake

 INFORMATION

If you apply the front wheel and rear wheel brakes evenly and almost simultaneously, you can usually control your pedelec better while braking and reduce your braking distance.

- Pull the brake lever towards the handlebar grip to brake the corresponding wheel.
 - Pull the brake lever harder or all the way to increase or maximise the braking power ("emergency braking").
 - Pull the brake lever less abruptly or release it to reduce the braking power or to stop braking.

25.4 Bedding in disc brakes

If a disc brake is new or has been fitted with new brake pads, always bed it in before using your pedelec regularly.

- Make sure that you
 - bed-in your disc brake away from road traffic,
 - follow any additional manufacturer's instructions for bedding-in your disc brake,
 - always remain seated on the saddle when braking for safety reasons and
 - when bedding in, do not brake your pedelec to a complete standstill, but simply drop the speed to a walking pace as described below.
- Accelerate your pedelec to a speed of around 24 km/h and then brake hard and evenly to drop to a walking pace. The wheels should not lock in the process!
- Repeat this process up to 50 times. You will notice that the brakes become more effective after each braking action.
- Allow the brake discs and brake pads to cool down after bedding them in or before your first ride.
- After bedding-in the disc brake, check the gripping distance of the brake levers and adjust, if necessary:
- The distance between the handlebar grip and the brake lever should be at least 1 cm and you should be able to operate the brake lever safely while riding without taking your hand off the handlebar.
- If the disc brake does not operate effectively after being bedded-in or if you hear unusual noises when braking, contact your specialist dealer.

25.5 Checking the disc brake

- Check that the brake lever and brake components are securely fastened.
 - Tighten any loose screw connections, if necessary.
 - If you notice or have the impression that any components are loose, contact your specialist dealer to have the brakes adjusted.
- Make sure that the brake lever is mounted on and aligned with the handlebar grip in such a way that you can operate it comfortably while cycling.
 - If necessary, loosen the brake lever mount and align the brake lever correctly. Then tighten the brake lever mount again.
- Check the distance between the brake lever when fully applied and the handlebar grip: The distance should be at least 1 cm.
 - If the distance is less than 1 cm, contact your specialist dealer to have the brake adjusted.
- Check whether the wheel is blocked when you pull the corresponding brake lever.
 - If the wheel is not sufficiently braked or blocked when you pull the brake lever, contact your specialist dealer to have the brake adjusted.
- Check how the brake pads move towards or away from the brake disc when you pull the brake lever and release it again: the brake pads should move evenly and symmetrically.
- Check the wear on the brake pads: the brake pads should wear or be used evenly on both sides of the brake disc.
 - If the brake pads wear unevenly or more heavily on one side, contact your specialist dealer to check the brake.
- Pull the brake lever as far as possible towards the handlebar grip and check whether any brake fluid leaks from the hydraulic line or the connection points to other components.
 - If any brake fluid is leaking, contact your specialist dealer to have the brake checked, and if necessary, serviced and adjusted correctly.

25.6 Adjustments

⚠ WARNING

Risk of accident and injury!

Loss of braking power due to incorrectly adjusted brake system.

» Adjustments to the brake system should be carried out by your specialist dealer.

Specialist knowledge is required to correctly adjust the brake system.

If you do not have the necessary expertise or the required tools, consult your specialist dealer.

25.6.1 Adjusting the brake lever

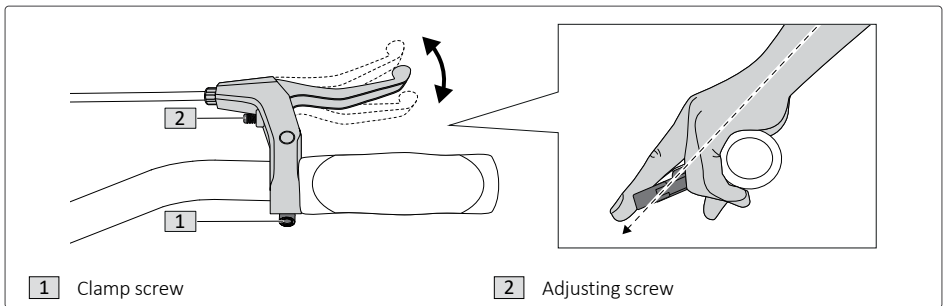

Fig. 12: Adjusting the brake lever

In order to guarantee maximum braking efficiency at all times, the position and gripping distance of the brake lever should be adjusted specifically for the cyclist.

Position of brake lever

1. Loosen the clamp screw.
2. Adjust the position.
3. Tighten the clamp screw.

Brake lever gripping distance

Increase gripping distance:

- Turn adjusting screw clockwise.

Decrease gripping distance:

- Turn adjusting screw anti-clockwise.

25.7 Wear and maintenance

The following components in particular are subject to wear, based on the method of operation and the design of the disc brake:

- brake pads,
 - brake discs,
 - brake fluid (hydraulic),
 - brake cables on the disc brake, if fitted.
- Check the brake pads, brake discs and brake cables, if fitted, regularly for signs of wear.
 - Contact your specialist dealer
 - if you are unsure or do not know how to recognise or comply with the wear limit of components.
 - to have the disc brake hydraulics checked and serviced, if necessary.
 - to have wear parts replaced and then have the disc brake re-adjusted.

25.8 Cleaning and care

Keep all disc brake components free from dirt or clean the components regularly to ensure that the disc brake continues to function correctly or to prevent any reduction in the braking power of the disc brake.

- Clean any soiled components with a damp cloth.
- In particular, wash the brake discs regularly with warm water to keep them free from (persistent) dirt.

GEAR SHIFT SYSTEM

26 General information

WARNING

Risk of accident and injury!

Due to inattentiveness in road traffic.

- » Familiarise yourself with the gear shift system before using the pedelec for the first time.
- » Shift through the different gears to familiarise yourself with the riding characteristics of the pedelec.
- » Only operate the gear shift system if this does not distract your attention from road traffic.
- » Come to a stop if you are unable to use the gear shift system safely, e.g. if it malfunctions.

NOTE

Risk of damage!

Damage to the gear shift system caused by improper use.

- » Do not pedal hard when shifting gears.
- » Do not pedal backwards when shifting gears.
- » Shift down gears in time before going uphill.
- » Only shift gears in acceleration-free/load-free phases.

The gear shift system allows the pedalling frequency and the amount of power required to propel the pedelec to be adapted to the riding conditions. The system features a model-dependent switch mechanism which is controlled via the relevant operating element(s).

27 Operating elements

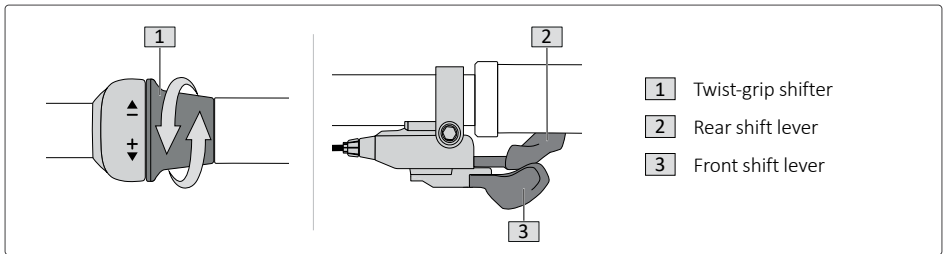

Fig. 14: Gear shift controls*

* Pedelects with electronic gear shift system, see > Chap. 30 "Electronic gear shift system" on page 63

28 Derailleur system

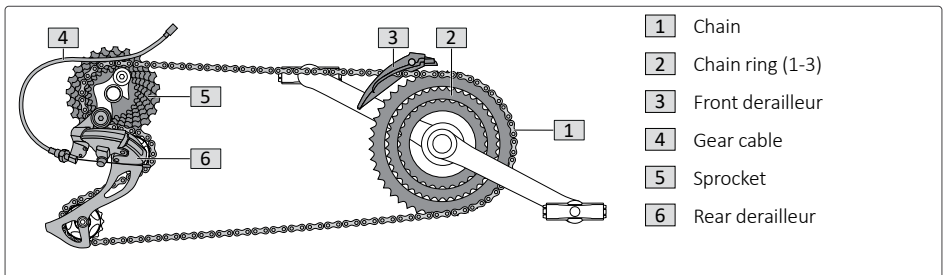

Fig. 15: Derailleur system components

28.1 Method of operation

Depending on the model, a pedelec with a derailleur system is fitted with 1 to 3 chain rings of different sizes at the same height as the pedals and 7 to 12 sprockets of different sizes at the rear wheel hub.

The different combinations of chain rings and sprockets over which the chain can run create the different gears (chain "transmission").

High transmission (more effort/lower pedalling frequency):

If the chain is running over one of the smaller sprockets, pedalling is harder, but the pedelec covers a longer distance for each pedal rotation.

Low transmission (less effort/high pedalling frequency):

If the chain is running over one of the larger sprockets, pedalling is easier, but the pedelec covers a shorter distance for each pedal rotation.

The required gear is selected using 1 or 2 operating elements on the handlebar, depending on the configuration.

28.2 Operating the derailleur system

Operating element for the front derailleur:

When shifting gears, the front derailleur shifts the chain to the required chain ring.

A small chain ring is recommended when riding uphill, while a larger chain ring is recommended for even stretches of road or downhill slopes.

Operating element for the derailleur system:

When shifting gears, the rear derailleur shifts the chain to the required sprocket.

> Chap. 28.1 "Method of operation" on page 59.

Operation:

- Always select the most suitable gear and maintain a pedal frequency of 60 to 100 rpm.
- Always start off in a low gear.
- As soon as the pedal frequency becomes too high, shift up a gear.
- As soon as the pedal frequency becomes too low, shift down a gear.

28.3 Checking the derailleur system

- Check the derailleur components regularly to ensure that they are functioning correctly and to prevent unnecessary wear.
 - Make sure that the chain, chain rings, sprockets, front derailleur, rear derailleur and gear cables are undamaged.
 - Make sure that the chain and rear derailleur are far enough away from the rear wheel or the spokes.
 - Make sure that the rear derailleur is positioned vertically in relation to the sprockets and is not bent.
 - Check the chain tension: The chain should not sag. If you push the rear derailleur forwards carefully (in the direction of the pedals), it should return to its original position automatically when released.
 - Lift the rear part of the pedelec so that you can move the rear wheel and turn the pedals to set the rear wheel gently in motion.
 - Shift through all the gears: Shifting should be easy; there should be no blockages or unusual noises.
- Contact your specialist dealer to:
 - replace any damaged or worn derailleur system components and then have the derailleur system adjusted again.
 - have the derailleur system checked and adjusted, if you notice any irregularities during the check.

28.4 Wear and maintenance

If maintained and cared for regularly, the derailleur system components generally show little sign of wear.

- Please note that the chain will wear more quickly if the angle at which it is running is too steep (e.g. if the chain is running on the smallest chain ring and the smallest sprocket). Avoid such combinations to prevent unnecessary chain wear.
- Check the derailleur system at regular intervals
> Chap. 28.3 "Checking the derailleur system" on page 60.
- Contact your specialist dealer to have the derailleur system serviced if:
 - unusual noises can be heard when shifting gears,
 - problems occur when shifting gears,
 - the chain comes off repeatedly.

28.5 Cleaning and care

- Keep all the derailleur system components free of dirt and clean the components regularly to ensure the derailleur system continues to function correctly.
 - Clean the operating elements with a damp cloth.
 - Remove coarse soiling from the chain rings and sprockets as well as from the front derailleur and rear derailleur using a damp cloth or a soft brush.
 - After cleaning, lubricate the chain rings, sprockets, front derailleur and rear derailleur with multi-purpose oil. Afterwards, wipe up any excess oil with a clean cloth.

29 Hub shifting system

29.1 Method of operation

The hub shifting system is installed in the rear wheel hub and operated by using a twist-grip shifter with a gear indicator on the right side of the handlebar.

The number of gears depends on the model.

29.2 Operating the hub shifting system

- To shift up or down a gear, turn the twist-grip shifter in the desired direction.
- If you have never used a hub shifting system or are unsure how to operate it, ask your specialist dealer to show you how.

29.3 Checking the hub shifting system

- Check the components of the hub shifting system regularly to ensure that it continues to operate correctly and to prevent unnecessary wear.
 - Make sure that the chain, chain rings and gear cables are undamaged.
 - Check the chain tension: The chain should not sag.
 - Lift the rear part of the pedelec so that you can move the rear wheel and turn the pedals to set the rear wheel gently in motion.
 - Shift through all the gears: Shifting should be easy; there should be no blockages or unusual noises.
- Contact your specialist dealer to:
 - replace any damaged or worn components on the hub shifting system and re-adjust the hub shifting system again afterwards.
 - to check the hub shifting system and adjust it, if necessary, if you notice any irregularities during the check.

29.4 Wear and maintenance

If maintained and cared for regularly, the components of the hub shifting system generally show little sign of wear.

- Check the hub shifting system at regular intervals
> Chap. 29.3 "Checking the hub shifting system" on page 62.
- Contact your specialist dealer to have the hub shifting system serviced if:
 - unusual noises can be heard when shifting gears,
 - problems occur when shifting gears.

29.5 Cleaning and care

- Keep all the components of the hub shifting system free of dirt and clean the components regularly to ensure the hub shifting system continues to function correctly.
 - Clean the operating elements with a damp cloth.
 - Remove coarse soiling from the chain ring and sprocket with a damp cloth or a soft brush.
 - After cleaning, lubricate the chains, chain ring and sprocket with multi-purpose oil. Afterwards, wipe up any excess oil with a clean cloth.

30 Electronic gear shift system

The electronic gear shift system has separate controls. The buttons for shifting gears can be pressed in quick succession. The gear shift system detects how many times the buttons are pressed and shifts to the relevant gear.



INFORMATION

Read and observe the instructions enclosed with the electronic gear shift system and contact your specialist dealer if you have any questions.

WHEELS

31 General information

 **WARNING****Risk of accident and injury!**

There is an increased risk of accident and injury if the wheels, for example, do not rotate concentrically (true running) or wobble. The rim can break and the rim brakes may block.

» Contact your specialist dealer to have the wheels aligned if they are not rotating concentrically or are wobbling.

 **WARNING****Risk of accident and injury!**

Dirty or missing reflectors impair your visibility in road traffic. There is an increased risk of accidents as a result.

» Remove any dirt from the reflectors and replace worn or missing reflectors immediately.

 **WARNING****Risk of accident and injury!**

There is an increased risk of accidents and injury if damaged tyres burst when cycling.

» Check the tyres regularly for damage and signs of wear.
» Do not use the pedelec if the tyres are not intact.

 **WARNING****Risk of accident and injury!**

There is an increased risk of accidents and injury if you cycle with the incorrect tyre pressure (too high or too low).

» Observe the specifications for the maximum and minimum tyre pressure for your tyres.
» Contact your specialist dealer if you are uncertain about the correct tyre pressure for your tyres.

NOTE**Risk of damage!**

Unsuitable tyres can affect or impair the proper functioning of pedelec components.

» Contact your specialist dealer if you have questions about tyre size or are unsure.

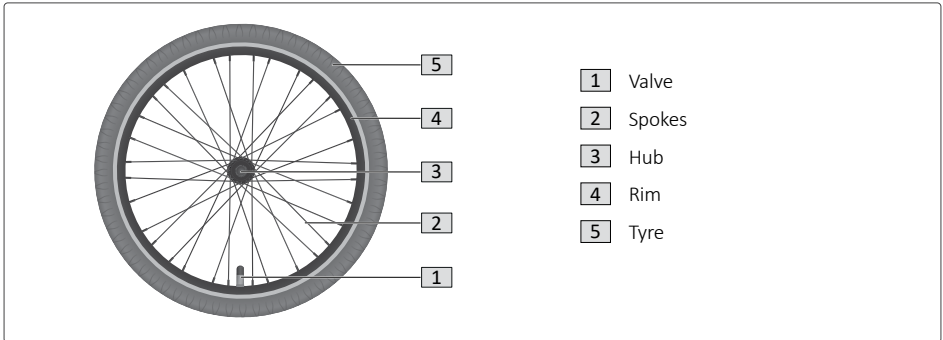

Fig. 16: Wheels

The weight of the person riding and uneven cycling surfaces place stress on the wheels.

- After an initial riding period, contact your specialist dealer to have the wheels checked and re-centred, if necessary, but no later than after:
 - the first 500 km distance travelled,
 - 25 to 50 hours of use,
 - 2 months, depending on which occurs first.
- Check the wheels every six months to ensure they are in a good condition:
 - The wheels should be free from damage and aligned correctly.

31.1 Rims and spokes

Correct and even tensioning of the rims stabilises the concentricity of the wheels. If the wheel is not running true, the stability of the rim is affected and the rim can break as a result. If a cyclist rides over an obstacle (e.g. a kerb) quickly or if a spoke nipple becomes loose, the spokes may no longer be tensioned correctly.

31.2 Tyre types

Tyres and rims are not usually airtight, but contain an inner tube that is filled with air via the valve. The only exceptions to this are tubular tyres and UST tyres, which are airtight systems that do not contain an additional inner tube.

The tyre size (mm or ") is usually specified on the side of the tyre.

31.3 Valve types

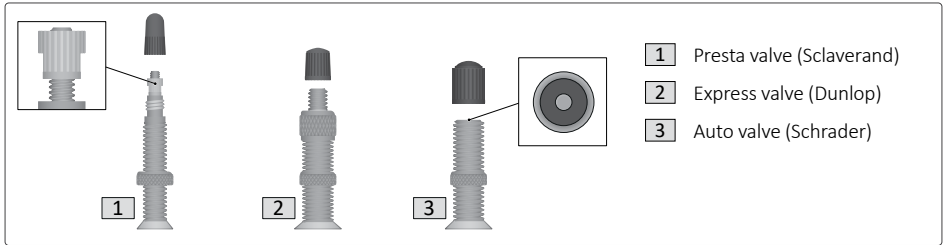

Fig. 17: Valve types

Depending on the type of valve fitted on the tyre or tube, you will need a compatible valve connector or adapter to inflate the tyre.

- If necessary, ask your specialist dealer which valve connector or adapter you need for your tyre.

Presta valve (Sclaverand)

- To open the valve, turn the valve screw upwards (in an anti-clockwise direction).
- To let air out of the tyre, push down the valve screw (without the valve connector/ adapter attached).
- To close the valve, turn the valve downwards (in a clockwise direction).

Express valve (Dunlop)

- To let air out of the tyre, turn the top valve nut upwards (in an anti-clockwise direction).
- To replace the valve insert, unscrew the top valve nut completely (in an anti-clockwise direction).
- To close the valve, turn the valve nut down completely (in a clockwise direction).

Auto valve (Schrader)

- To let air out of the tyre, push in the metal pin inside the valve.

31.4 Tyre pressure

INFORMATION

The tyre pressure affects the rolling resistance and suspension of the pedelec.

There are usually two values printed on the tyres, each specifying the maximum tyre pressure.

The lower value applies to:

- Lighter cyclists,
- Cycling over uneven surfaces.

The higher value applies to:

- Heavier cyclists,
- Cycling over even surfaces.
- Check the tyre pressure at regular intervals.
 - If necessary, pump up the tyre or let air out of the tyre if the tyre pressure does not match the specifications or is not suitable for the journey you are planning.

32 Pumping up tyres

1. Use a bicycle pump with a valve connector/adaptor that is compatible with your valve.
2. Remove the protective cap from the valve.
3. Check the tyre pressure using a pressure gauge or a bicycle pump fitted with a pressure gauge.
4. Pump up the tyre or let air out until you reach the correct tyre pressure.
5. Fit the previously removed protective cap back on the valve.
6. Then check that the bottom valve nut is screwed on correctly and securely. If necessary, turn the nut clockwise to tighten.

33 Regular checks

- Check the tyres.
 - To do this, check if:
 - The tyres are showing cracks or damage.
 - The tyre has sufficient tread or is too worn and needs to be replaced.
 - Contact your specialist dealer to have damaged or worn tyres replaced.
- Check the rims.
 - To do this, check if the rims are showing any cracks or damage.
 - Check for indentations on the rim using your fingernail or a toothpick. If you notice any indentations on the rim, the wear limit has been reached and the rim must be replaced.
 - Contact your specialist dealer to check whether the rims are worn.
 - Contact your specialist dealer to have damaged or worn rims replaced.
- Check the spoke tension.
 - To do this, carefully press two spokes together to see whether they are evenly tensioned.
 - If you notice that individual spokes have loosened, contact your specialist dealer to have the spokes tightened.

SADDLE

The shape of the saddle should be suitable for the intended use and match the physical characteristics and personal preferences of the rider.

If the saddle is set to the optimum position, you should be able to easily reach all operating elements on the handlebar in a comfortable sitting position and put your feet on the ground to support yourself.

34 Adjusting the saddle



WARNING

Risk of accident and injury!

Failure to observe the minimum insertion depth for the seat post can cause the seat post to slip or break and/or the frame to break.

- » Always observe the minimum insertion depth for the seat post.
- » Never shorten the seat post arbitrarily.

NOTE

Risk of damage!

Failure to observe the specified minimum extension height of the seat post can damage certain pedelec components.

- » When adjusting the saddle height, take care not to damage any cables, bowden cables or similar running through the seat tube.



INFORMATION

Minimum insertion depth of the seat post

There is usually a mark on the seat post which indicates the minimum depth the seat post must be inserted into the seat tube.

If you have adjusted the saddle height correctly, the mark for the minimum insertion depth of the seat post should no longer be visible but rather should be inside the seat tube.

Minimum extension height of the seat post

Additional information about the minimum extension height of the seat post may be specified, depending on the bike model.

The corresponding value indicates how far the seat post should extend out of the seat tube as a minimum requirement.

34.1 Adjusting the saddle height

Quick-release clamp

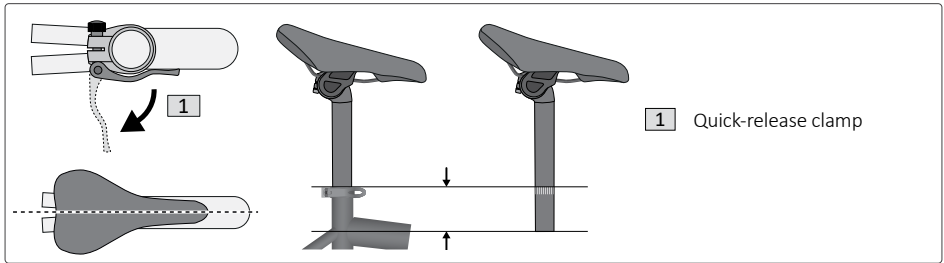

Fig. 18: Adjusting the saddle height (quick-release clamp)

1. Swivel the quick-release lever outwards.
2. Adjust the saddle to the required height.
 - When doing this, observe the minimum insertion depth of the seat post.
3. Once you have adjusted the saddle to the correct height, align the saddle in a straight line with the frame.
4. To secure the saddle in position, swivel the quick-release lever inwards until it is flush with the seat tube.
 - If you cannot swivel the quick-release lever in as far as the seat tube, you can reduce the initial tension by turning the adjusting screw in an anti-clockwise direction.
 - Then swivel the quick-release lever inwards again until it is flush with the seat tube in order to close the seat post clamp.
5. Check whether the saddle can be rotated.
 - If you can rotate the saddle, increase the initial tension of the quick-release clamp by turning the adjusting screw in a clockwise direction.

Clamp with clamp screw

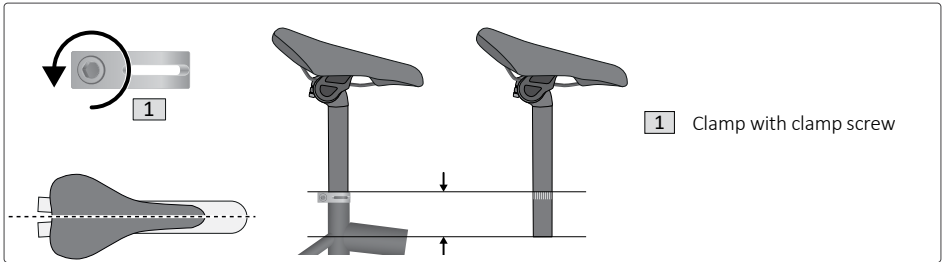

Fig. 19: Adjusting the saddle height (clamp with clamp screw)

1. Turn the clamp screw in an anti-clockwise direction until the seat post can be moved in the seat tube.
2. Adjust the seat post to the required height.
 - When doing this, observe the minimum insertion depth of the seat post.
3. Once you have adjusted the saddle to the correct height, align the saddle in a straight line with the frame.
4. To secure the saddle in position, turn the clamp screw in a clockwise direction and tighten.
 - When doing this, observe the torque of the clamp screw > Chap. 12.1 on page 29.
5. Check whether the saddle can be rotated.
 - If you can rotate the saddle, check the seat post clamp.

34.2 Adjusting the saddle position

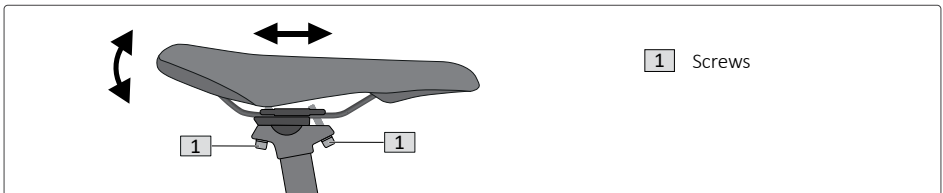

Fig. 20: Adjusting the saddle position

1. Release the screws on the seat post in an anti-clockwise direction.
2. Tilt and move the saddle to the desired position.
3. To secure the saddle in position, tighten the screws on the seat post in a clockwise direction.
 - When doing this, note the torque of the screws > Chap. 12.1 on page 29.
4. Check whether the saddle can be rotated.
 - If the saddle can be rotated, contact your specialist dealer.

HANDLEBAR

35 Adjusting the handlebar

NOTE

Risk of damage!

In the case of a threadless handlebar stem, the head bearing can become damaged if you adjust the handlebar direction incorrectly.

» Only tighten the top screw on the threadless handlebar stem until the head bearing is fixed in position, but the bearing and handlebar can still move freely.

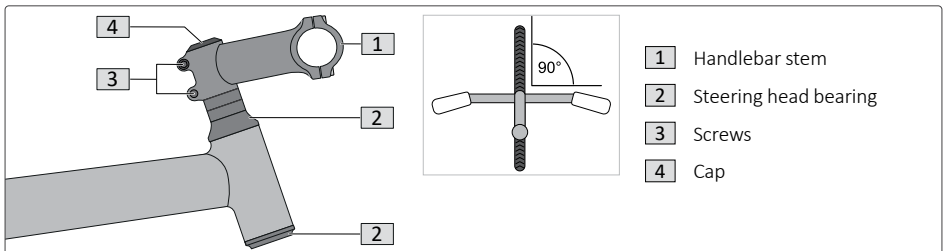

Fig. 21: Adjusting the handlebar stem (clamp with clamp screw)

1. Remove the cover cap from the top of the handlebar stem.
2. Release the screw underneath by one revolution in an anti-clockwise direction.
3. Release the screws on the shaft clamp until you can turn the handlebar against the front wheel.
4. Adjust the head bearing as described below.
 - Tighten the screw on top of the handlebar stem in gradual steps (approx. $\frac{1}{8}$ of a revolution in a clockwise direction for each step).
 - When doing this, keep the brake for the front wheel pressed down.
 - If you now try to push the pedelec backwards and forwards, the head bearing should remain secured in position and should be free of play.
 - Lift the pedelec by its frame. If you then tilt the frame to one side, the front wheel should be able to rotate in this position as well as move to the left or right by itself.
5. Align the handlebar at an angle of 90° in relation to the front wheel.
6. Tighten the screws on the shaft clamp.
 - When doing so, note the torque of the screw > Chap. 12.1 on page 29.
7. Replace the cap on top of the handlebar stem.

SUSPENSION FORK

36 General information

 **WARNING****Risk of accident and injury!**

Incorrectly adjusted suspension can affect the road-holding capability of your pedelec (depending on the condition of the road surface), which may increase the risk of accidents and injuries. Improper handling of suspension components under tension can result in injury.

- » Contact your specialist dealer to set up the suspension system for you.
- » Always ask your specialist dealer to remove or repair suspension components.

NOTE**Risk of damage!**

Incorrect adjustment or handling can adversely affect your riding comfort and damage the pedelec and the suspension components.

- » Contact your specialist dealer to adjust the pneumatic suspension components.
- » If you hear unusual noises or feel strong impacts when the bike springs up and down, ask your specialist dealer to inspect the suspension components.

NOTE**Risk of damage!**

Permanent activation of the lock-out function increases wear on the relevant suspension components.

- » Only use the lock-out function if it significantly improves your riding performance.
- » Make sure that you deactivate the lock-out function again when the cycling conditions permit this.

A suspension system adapted specifically to the cyclist increases riding comfort and safety on uneven surfaces.

Depending on the model, your pedelec may be fitted with a suspension fork instead of a conventional front fork. The suspension fork helps the front wheel to absorb bumps and unevenness on the road.

36.1 Method of operation and terms

When the suspension is compressed, the corresponding damper rods retract into their mounts and compress the springs inside the suspension component. When the suspension is released, the spring inside pushes the damper rods back into their original position.

The spring tension determines the stiffness of the suspension fork under load and the resistance of the suspension fork to compression.

Hydraulic dampers ensure controlled, adjustable compression. The compression and release stages of the dampers determine the speed at which the spring compresses or rebounds.

As a general rule:

- The higher the stiffness setting of the damper's compression or release stage, the more sluggishly the suspension fork moves;
- Conversely, the lower the setting, the more easily/quickly the suspension fork returns to its original position.

Sag refers to compression of the suspension by the body weight of the rider. The ideal sag for a suspension fork is usually 15-30% of the total compression distance.

The suspension should compress proportionately to the weight of the cyclist sitting on the saddle.

36.2 Spring tension and lock-out function

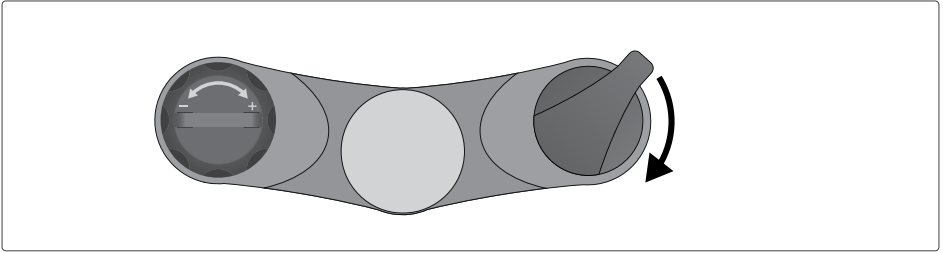

Fig. 22: Spring tension (left) and lock-out function (right) on the suspension fork

Adjusting the spring tension

If your pedelec features mechanical suspension with steel or titanium springs, you can usually adjust the spring tension yourself if you have the necessary technical knowledge.

1. Remove the cover cap from the left stand tube, if present.
2. Turn the rotary knob on the stand tube:
 - in a clockwise direction (+) to increase the spring tension.
 - in an anti-clockwise direction (-) to decrease the spring tension.

Make sure that the spring tension is adjusted to the same stiffness setting on both sides.

3. If you are unsure how to adjust the suspension or experience problems when doing so, please consult your specialist dealer.

Lock-out function

The lock-out function is activated using the rotary knob on the right stand tube of the suspension fork.

- Activate the lock-out function by turning the rotary knob one quarter of a turn in a clockwise direction.
- Deactivate the active lock-out function by turning the rotary knob one quarter of a turn in an anti-clockwise direction.

INFORMATION

You can use the lock-out function to lock the suspension fork completely, e.g. if you are pedalling hard and the suspension is adversely affecting your progress or riding comfort.

- Please note that the suspension can compress by up to 15 mm on uneven road surfaces, even when the lock-out function is activated.

36.3 Wear and maintenance

If you hear unusual noises when the bike springs up and down or you have the impression that the suspension is not offering any compression resistance, contact your specialist dealer to inspect the suspension components.

36.4 Cleaning and care

- Make sure that the sliding surfaces and seals on the suspension are free from dirt.
 - Remove any dirt with a clean cloth and a dab of oil applied, if necessary.
- After cleaning, apply a small quantity of lubricant to the sliding surfaces, e.g. multi-purpose oil. If necessary, consult your specialist dealer for advice on suitable lubricants and care products.
 - After lubricating, push down on the suspension five times to compress it.
 - Afterwards, wipe up any excess lubricant with a clean cloth.

OTHER COMPONENTS

37 Lights

37.1 General information

In order to use a pedelec on the road e.g. in Germany (Road Traffic Licensing Regulations), it must be fitted with the following lighting components:

- Headlight
- Rear light
- Reflectors on the pedals
- Side reflectors or reflective strips
- White front reflector
- Red rear reflector

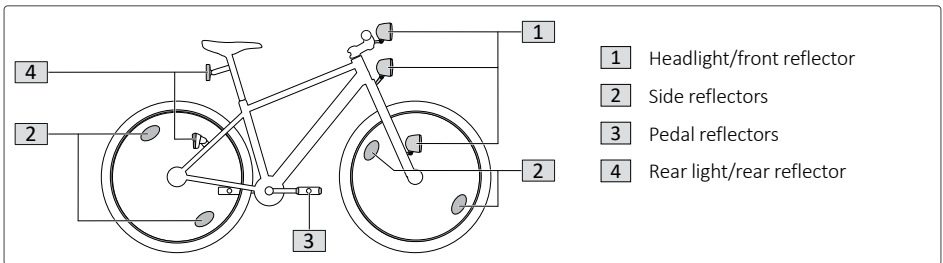

Fig. 23: Lighting components on the pedelec

- Only use the pedelec on public roads if all lighting components meet national and regional requirements.
- Familiarise yourself with national laws and regulations.
- Have any faulty lights replaced by your specialist dealer.

Depending on the model, the headlight and rear light are powered by a dynamo, a separate battery or a rechargeable battery integrated into the lighting component.

37.2 Mounting points

Depending on the model, the headlight and rear light are mounted on one of the following mounting points:

Headlight/front reflector

- on the handlebar
- on the head tube
- on the fork

Rear light/rear reflector

- on the carrier
- on the mudguard
- on the seat stay

37.3 Switching the lights on and off

 **WARNING**

Risk of accident and injury!

Riding with inadequate lighting or without any lighting makes it difficult for other road users to see you and prevents you from spotting dangers (e.g. obstacles).

» Always switch on the lights before riding in low visibility (e.g. fog, dusk) or in the dark.

 **WARNING**

Risk of accident and injury!

If you become distracted when switching on the lights while riding, there is an increased risk of accident and injury.

» Switch on the lights before setting out, or stop to switch on the lights.

 **WARNING**

Risk of accident and injury!

If the beam of light from a headlight is too bright, it may dazzle oncoming road users. There is a risk of accident and injury.

» Adjust the headlight away from oncoming road users so that they are not dazzled by the light.

Sidewall dynamo-powered lighting

- The light is enabled by pressing down on the pressure point on the dynamo so that the dynamo rests against the side of the wheel.
- The light is disabled by pushing the dynamo away from the side of the wheel back to its original position.

Hub dynamo light or separate battery

- The light is enabled by setting the on/off switch to position I (ON).
- The light is disabled by setting the on/off switch to position II (OFF).

38 Quick-release clamp

WARNING

Risk of accident and injury!

If quick-release clamps are not closed or adjusted properly, they can open while you are riding and cause the corresponding components to come loose.

- » Before setting off, make sure that all quick-release clamps are closed properly with sufficient initial tension and resting against the component or frame.
- » You should only remove or install wheels with quick-release axles yourself if you have sufficient technical knowledge. Otherwise, contact your specialist dealer.

CAUTION

Risk of injury!

If you operate a quick-release clamp without due care, you could crush your fingers.

- » Take extra care when opening and closing the quick-release clamp and take care not to get your fingers caught.

Components secured with quick-release clamps are quick to adjust, remove and install without using tools.

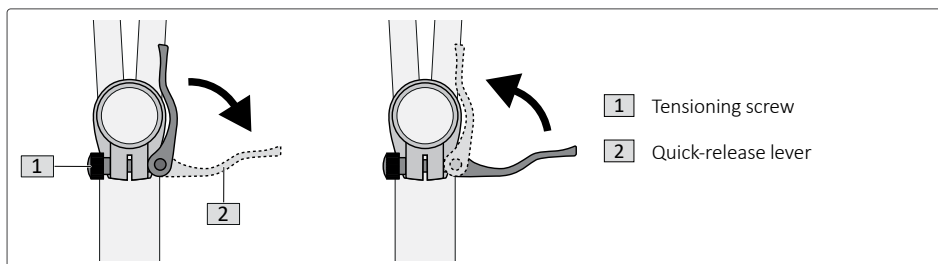

Fig. 24: Quick-release clamp

Opening and closing a quick-release clamp

- Open the quick-release clamp by pulling the lever outwards (away from the component that it is resting against when closed).
- Close the quick-release clamp by pushing the lever against the corresponding component until it is resting against it.
- The quick-release clamp should be adjusted if you notice that it is not holding the component securely in place or if it closes too easily.
- Have your specialist dealer replace any worn or damaged quick-release clamps with suitable original spare parts.

Adjusting a quick-release clamp

1. Open the quick-release lever.
2. Turn the tensioning screw clockwise one quarter of a revolution.
3. Close the quick-release lever.
4. Then check whether the quick-release clamp is securing the component properly.
Repeat the process until the quick-release clamp is securing the component properly when closed.

If you cannot secure the component properly, contact your specialist dealer.

39 Bell

Depending on the model, the pedelec is fitted with a bell on delivery. If the pedelec is not fitted with a bell, you can retrofit one.

- In case of any questions, consult your specialist dealer.

To enable you to give clearly audible acoustic signals for the benefit of other road users while cycling, the pedelec must be fitted with an appropriate bell prior to use on public roads.

- If the bell attached to the pedelec does not make a clearly audible sound, contact your specialist dealer to have the bell replaced.
- Position the bell on the handlebar so that you can easily reach it without taking your hand off the handlebar grip.

40 Carrier

NOTE

Risk of damage!

Installing or using a carrier incorrectly can damage components on the pedelec.

- » If you wish to retrofit an optional carrier to the pedelec, make sure that the pedelec is suitable for mounting a carrier. Have your specialist dealer mount your carrier for you.
- » If you are fitting a carrier for the first time or changing the carrier, always use carriers certified according to DIN EN ISO 11243.
- » Do not make any structural modifications to the carrier as this could affect its stability.
- » When loading the carrier, observe the information about the carrier's maximum load capacity and the maximum permissible total weight of the pedelec.

The carrier is suitable for transporting lightweight baggage secured to the carrier using a clamping system, clamp bracket or lashing straps.

- Refer to the imprint on the carrier for information about the carrier's maximum load capacity, otherwise contact your specialist dealer.
- Observe the information on using the carrier
 - > Chap. 47.1 "Using carriers" on page 91.

41 Stand

INFORMATION

Depending on the model, the pedelec is fitted with a stand on delivery.

- If the pedelec is not fitted with a stand, contact your specialist dealer. Your dealer will tell you whether a stand can be retrofitted to your pedelec.

When parking the pedelec, you can use the stand as a support so that your bike stays upright.

If you wish to park the pedelec:

1. Hold the pedelec.
2. Use your foot to fold out the stand until it engages.
3. Carefully lean the pedelec against the stand.
4. Once the pedelec is standing securely, you can let it go.

If you want to use or move the parked pedelec:

1. Hold the pedelec.
2. Stand the pedelec upright to take the weight off the stand.
3. Use your foot to fold in the stand until it engages.

Depending on the model, you can adjust the position/alignment of the stand so that it supports the pedelec securely.

- Adjust the stand if it does not support the pedelec properly.
- If you are unsure how to adjust the stand or experience problems when doing so, consult your specialist dealer.

STORAGE AND TRANSPORTATION

42 Storing the pedelec

 **WARNING****Risk of accident and injury!**

If the e-drive is started inadvertently or if children or persons with physical or mentally disabilities have access to your pedelec, accidents and serious injuries may result.

- » Always remove the battery before parking or storing your pedelec for an extended period of time.
- » Secure and park your pedelec so that unauthorised persons (especially children) cannot access it.

NOTE**Risk of damage!**

Improper storage can damage the e-drive or its components.

- » Observe the storage temperatures for the components of the e-drive to avoid damage and functional impairment.
- » Observe the storage information in the corresponding manufacturer's instructions for the e-drive (especially the battery) and other pedelec components, if necessary.

1. Clean the pedelec before storing it away for longer periods
> Chap. 44.3 "Cleaning and maintaining the pedelec" on page 87.
2. If the pedelec is fitted with a derailleur system, shift to the small chain ring at the front and the smallest sprocket at the rear to relieve the cables as much as possible.
3. Store the pedelec in a dry room protected from freezing temperatures and major temperature fluctuations.
4. Hang up the pedelec by the frame, if necessary, to prevent the tyres from deforming.
5. Store the battery, charger and other components separately from the pedelec and observe the information in the corresponding manufacturer's instructions.

43 Transporting pedelecs



WARNING

Risk of accident and injury!

If the e-drive is started inadvertently, it may cause accidents and serious injuries.

- » Always remove the battery before parking or storing your pedelec for an extended period of time.

NOTE

Risk of damage!

Improper transportation can damage the pedelec or the e-drive and its components.

- » Secure the pedelec so that it cannot slip or fall during transport.
- » Transport the battery with care and make sure that it is protected against shocks and impacts.
- » In addition to the battery, remove any other sensitive or delicate components (e.g. the display) from the pedelec before transporting it, or protect the components in some other way to avoid damage during transport.
- » Observe the transport information in the corresponding manufacturer's instructions for the e-drive and other components, if necessary.
- » Switch off the e-drive and remove the battery from the pedelec.

1. If your pedelec is fitted with a disc brake that has a transport lock, attach the transport lock, if necessary.
 - Ask your specialist dealer to explain how to operate the transport lock.
2. Mount the pedelec on the bike rack prior to transportation. Observe the information in the manufacturer's instructions for the bike rack and other components, if necessary.
 - Only use approved bike racks that are capable of transporting the pedelec in an upright position.
 - For more information on suitable bike racks, contact your specialist dealer.

If you plan on transporting the pedelec in a bus, aeroplane, ship or train:

- Before starting your journey, contact the relevant transport company for information on the conditions for transporting the battery and the pedelec.

DISPOSAL

Dispose of the packaging according to the type of material.

- Dispose of card and cardboard in your waste paper container and films in your plastic recyclables container.

Dispose of lubricants, cleaning agents and care products in line with environmental regulations. These items must not be disposed of with domestic waste, sewer systems or into the environment.

- Read the information on the packaging.
- Dispose of lubricants, cleaners and maintenance products at a collection point for hazardous waste.

Tyres and inner tubes do not qualify as residual or domestic waste.

- Dispose of inner tubes and tyres at a recycling centre or collection point run by the local city council or municipality.

Pedelec Disposing of the pedelec

	<p>The EU Directives on waste electrical equipment (Directive 2012/19/EU) and waste batteries (Directive 2006/66/EC) apply to the disposal of a pedelec, whereby the relevant components must be collected separately and disposed of according to environmental regulations. As a consumer, you are legally obliged to return electrical and electronic equipment as well as all types of battery to special public collection points or specialist dealers at the end of their service life.</p>
--	--

1. Remove the battery that supplies energy to the e-drive and, if necessary, remove any other batteries fitted to the pedelec as well as all components and operating elements that contain batteries, from the pedelec.
2. Dispose of your pedelec (without batteries) as waste electrical equipment.
 - Ask the local authorities or municipality about free collection points for waste electrical equipment and/or collection points for recycling waste electrical equipment.
 - If applicable, delete any personal data stored on auxiliary equipment before you hand over your pedelec to the collection point. This task is your responsibility.
3. Dispose of the removed battery and any other batteries removed from the pedelec as hazardous waste at a recycling centre or a collection point in your city or municipality.

HOW TO HANDLE THE PEDELEC

44 Overview of the operating steps

INFORMATION

This section provides a summary and a brief description of the steps required to use the pedelec.

Detailed descriptions of the individual functions and processes, including all relevant information and warnings, are included in the separate sections for the relevant components.

- Read the separate detailed sections fully before using the pedelec for the first time. It is not enough just to read this "How to handle the pedelec" section!
- Refer back to the separate detailed sections if you are unsure of how to use the pedelec or have any problems when using it.

44.1 Preparation

If you are riding the pedelec for the first time

1. Adjust the saddle and handlebar correctly so that you are seated correctly while riding the pedelec
 - > Chap. 34 "Adjusting the saddle" on page 69 *and*
 - > Chap. 35 "Adjusting the handlebar" on page 72.
2. Familiarise yourself with your pedelec
 - > Chap. 15 "Familiarise yourself with the pedelec" on page 34.
3. Check the components of the pedelec before setting off
 - > Chap. 16 "Check your pedelec before you start riding." on page 34.

You are already familiar with the pedelec or use it regularly

- Check the components of the pedelec before setting off
 - > Chap. 16 "Check your pedelec before you start riding." on page 34.

44.2 Using the pedelec

Brakes

> Chap. 25.3 "Operating the disc brake" on page 53

- Pull the brake lever towards the handlebar grip to brake the corresponding wheel.
 - Pulling the brake lever harder or all the way increases or maximises the braking power ("emergency braking").
 - Pulling the brake lever more gently or releasing it reduces the braking power or stops braking altogether.

Shifting gears

> Section "Gear shift system" on page 58

- Use the gear shift operating element to change to a higher or lower gear.

Transporting baggage

> Chap. 47 "Transporting baggage" on page 90

- Transport baggage on the carrier or in a trailer, if necessary. Use suitable bicycle bags to store baggage safely.

Transporting children

> Chap. 46 "Riding with children" on page 89

- Transporting children in child seats or child trailers is not permitted. > Section "Bicycle passport" on page 96.

44.3 Cleaning and maintaining the pedelec

Clean the pedelec and components fitted to the pedelec on a regular basis.

Pedal drive / components

> Chap. 19.3 "Cleaning and care" on page 38

E-drive

> Chap. 21.6 "Cleaning and care" on page 47 and the manufacturer's instructions accompanying the e-drive

Front wheel and rear wheel brake

> Chap. 25.8 "Cleaning and care" on page 57

Gear shift components

> Chap. 28.5 "Cleaning and care" on page 61

44.4 Regularly checking the pedelec components

Check the condition and function of the components fitted to the pedelec every six months:

Pedal drive / components

> Chap. 19.2 "Wear and maintenance" on page 38

E-drive

> Section "Special characteristics of the e-drive" on page 39 and the manufacturer's instructions accompanying the e-drive

Front wheel and rear wheel brake

> Chap. 25.7 "Wear and maintenance" on page 57

Gear shift components

> Chap. 28.3 "Checking the derailleur system" on page 60

> Chap. 28.4 "Wear and maintenance" on page 61

45 After a fall



WARNING

Risk of accident and injury!

Damaged pedelec components can break suddenly or fail in some other way.

- » Do not use your pedelec if it is damaged or you suspect it is damaged.
- » Have your pedelec checked by your specialist dealer after a fall or accident.
- » Have damaged components replaced with suitable original parts.
- » Never try to straighten bent parts yourself.

Accidents and falls can cause damage to the pedelec that may not be visible at first glance, e.g. hairline cracks.

- After a fall, always have your specialist dealer replace any carbon components with suitable original parts.
- If the fall occurred with the battery fitted: stop using the battery and replace it with a suitable original battery. Please also observe the manufacturer's instructions accompanying the e-drive.
- If the pedelec tips over during a minor fall, for example, check the condition and function of the components installed on the pedelec.

46 Riding with children

Transporting children in child seats or child trailers is not permitted.

Observe the information in the bicycle passport > Section "Bicycle passport" on page 96.

47 Transporting baggage



WARNING

Risk of accident and injury!

Transporting baggage incorrectly compromises road safety. There is an increased risk of accident and injury.

- » Do not attach any baggage to the handlebar. Specially designed handlebar bags are the only exception to this.

NOTE

Risk of damage!

Using carrier and/or trailer incorrectly can damage components on the pedelec.

- » When transporting baggage, observe the information on the maximum load capacity of the carrier or trailer and the maximum permissible total weight of the pedelec.
- » Do not use carrier and/or trailer with unsuitable pedelecs.

Using a trailer with your pedelec is not permitted.

Observe the information in the bicycle passport > Section "Bicycle passport" on page 96.

47.1 Using carriers



WARNING

Risk of accident and injury!

Loading the carrier incorrectly compromises road safety. There is an increased risk of accident and injury.

- » Secure the baggage to the carrier to prevent it from slipping or falling off. Only use undamaged lashing straps or similar.
- » Make sure that the centre of gravity of the baggage is in the centre.
- » Only use suitable bike bags from specialist retail outlets.
- » Please keep in mind that the riding characteristics of your pedelec may change due to the additional weight.



CAUTION

Risk of injury!

Your fingers may get trapped in the clamping brackets and the lashing straps may snap back and injure you.

- » Do not let go of the clamping brackets and/or lashing straps abruptly, but release them carefully until they are slack.
-
- Load the carrier in such a way that lighting components (headlight, rear light, reflectors) are not obscured.
 - When loading heavier items of baggage, make sure that they are placed in bike bags as far down as possible to achieve a low centre of gravity.
 - Always ensure that the lashing straps or similar are fixed securely and cannot get trapped in moving parts.

WARRANTY CONDITIONS

We would encourage you to use the IDEAL BIKE WARRANTY CARD so that we can offer you the best possible service. The warranty includes replacement of the frame in the event of a material or manufacturing fault. The fault must be verified by an IDEAL bicycle dealer within the warranty period. The warranty period begins on the date of purchase and is valid for 3 (three) years. The warranty also covers any material and manufacturing faults on all other components for two years from the date of purchase.

Claims under this warranty can only be asserted by the original owner on presentation of a dated original invoice. Please submit your claims to the IDEAL specialist bicycle dealer from whom you purchased the bicycle (pedelec). The warranty periods mentioned above will only be honoured if the bicycle (pedelec) has been serviced at least once a year by an IDEAL bicycle dealer in accordance with the requirements specified in these operating instructions.

You will find a 5-year maintenance plan for this purpose in the last section of the original operating instructions. The IDEAL bicycle dealer must confirm the annual inspections with a signature and a stamp. If you have owned your IDEAL bicycle (pedelec) for more than five years, you can photocopy the service plan and attach a copy. The owner of the IDEAL bicycle (pedelec) is responsible for bearing the costs of the inspection and servicing. In the event of a claim, IDEAL shall be free to choose between repairing or replacing the affected component. Parts that are not faulty shall only be replaced at the owner's expense. The handover certificate at the end of the operating instructions must be completed and signed by the customer. The IDEAL bicycle dealer shall retain a copy acknowledged and signed by the customer. When a warranty claim is submitted, the handover certificate must be presented together with the faulty part. Otherwise the warranty services cannot be granted.

EXCLUSION

Normal wear and tear is excluded from the warranty. Please read the next section to find out which components come under this category. The manufacturer of the IDEAL brand is not obliged to repair faults on bicycles (pedelecs) and/or their components caused by incorrect use, negligence, accidental damage, misuse, improper assembly and improper maintenance performed by anyone other than an IDEAL bicycle dealer. This warranty shall no longer be valid if the bicycle (pedelec) is modified or not used as intended, including, but not limited to, failing to follow the original operating instructions, using the bicycle (pedelec) in a competition or bicycle race, stunt riding, jumping on ramps or similar activities. IDEAL hereby provides a voluntary, limited manufacturer's warranty, which is granted under certain conditions specified exclusively in this document. This warranty does not affect the rights granted to the customer by law.

WARNING

Like any item of mechanical equipment, a bicycle (pedelec) and its components are subject to wear and stress. Different materials and mechanisms are exposed to varying degrees of wear and have different life cycles. If a component exceeds its life cycle, it can fail suddenly and injure the cyclist. Many maintenance tasks require specialist training, specialist qualifications, specialist knowledge and special tools. Do not attempt to make adjustments or perform maintenance work on your bicycle (pedelec) if you do not have the necessary expertise. Incorrect adjustments or improper maintenance work can damage the bicycle (pedelec) or cause an accident, resulting in serious injuries. Like any sport, cycling is associated with a risk of injury and damage. When you make the decision to ride a bike, you take responsibility for any associated risks. You must be aware of the rules for safe and responsible use and apply them accordingly.

IMPORTANT

In order to ensure that you continue riding safely, certain components such as forks, suspension forks and dampers must be regularly inspected and maintained in accordance with the enclosed manuals/operating instructions provided by the manufacturer. Please always ask an IDEAL bicycle dealer to perform this work.

As described in these original operating instructions, checking and inspecting the bicycle (pedelec) regularly in accordance with the manufacturer's instructions is essential for safe and reliable use. If the manufacturer's recommendations and instructions are not followed and the owner/user of the bicycle (pedelec) does not meet the regular maintenance and inspection requirements for the bicycle (pedelec), the owner/user of the bicycle (pedelec) shall assume responsibility for the risk of a major accident occurring. The manufacturer shall not be liable for this.

MAINTENANCE PLAN

1. Inspection

After approx. 500 km / 25-50 hours of use or 2 months*

Activities performed, parts replaced/repared:

.....
.....
.....
.....

..... Date, stamp/signature of specialist dealer:
.....
.....

2. Inspection

After approx. 1,000 km / 50-100 hours of use or at least once a year

Activities performed, parts replaced/repared:

.....
.....
.....
.....

..... Date, stamp/signature of specialist dealer:
.....
.....

3. Inspection

After approx. 2,000 km / 50-100 hours of use or at least once a year

Activities performed, parts replaced/repared:

.....
.....
.....
.....

..... Date, stamp/signature of specialist dealer:
.....
.....

* Within two months of purchase at the latest

4. Inspection

After approx. 3,000 km / 50-100 hours of use or at least once a year

Activities performed, parts replaced/repared:

.....
.....
.....
.....

..... Date, stamp/signature of specialist dealer:
.....
.....

5. Inspection

After approx. 4,000 km / 50-100 hours of use or at least once a year

Activities performed, parts replaced/repared:

.....
.....
.....
.....

..... Date, stamp/signature of specialist dealer:
.....
.....

6. Inspection

After approx. 5,000 km / 50-100 hours of use or at least once a year

Activities performed, parts replaced/repared:

.....
.....
.....
.....

..... Date, stamp/signature of specialist dealer:
.....
.....

Frame number: _____

Frame size: _____ Colour: _____

Model	Model ID	Category	Max. permitted total weight
<input type="checkbox"/> HILLMASTER-609 GTS 622 mtb	4029642 (M)	3	120 kg
<input type="checkbox"/> PRISMA-810X sport 622 sport	4029592 (M)	2	140 kg
<input type="checkbox"/> PRISMA-810FX WAV 584 trekking	4027522 (W)	2	120 kg
<input type="checkbox"/> PRISMA-810FX WAV 622 trekking	4029582 (W)	2	120 kg
<input type="checkbox"/> PRISMA-810FX GTS 622 trekking	4029572 (W)	2	140 kg
<input type="checkbox"/> PRISMA-810X WAV 584 trekking	4027512 (W)	2	140 kg
<input type="checkbox"/> PRISMA-810X WAV 622 trekking	4029562 (W)	2	140 kg
<input type="checkbox"/> PRISMA-610X WAV 584 trekking	4027502 (W)	2	140 kg
<input type="checkbox"/> PRISMA-610X WAV 622 trekking	4029552 (W)	2	140 kg
<input type="checkbox"/> PRISMA-610X LDS 622 trekking	4029542 (L)	2	140 kg
<input type="checkbox"/> PRISMA-610X GTS 622 trekking	4029532 (M)	2	140 kg
<input type="checkbox"/> PRISMA-610 WAV 584 trekking	4027612 (W)	2	140 kg
<input type="checkbox"/> PRISMA-610 GTS 622 trekking	4029632 (M)	2	140 kg
<input type="checkbox"/> PRISMA-609 WAV 584 sport+	4027602 (W)	2	140 kg
<input type="checkbox"/> PRISMA-609 WAV 622 sport+	4029622 (W)	2	140 kg
<input type="checkbox"/> FUTOUR-810X WAV 622 trekking	4028372 (W)	2	140 kg
<input type="checkbox"/> FUTOUR-810X LDS 622 trekking	4028362 (L)	2	140 kg
<input type="checkbox"/> FUTOUR-810X GTS 622 trekking	4028352 (M)	2	140 kg
<input type="checkbox"/> FUTOUR-610FX WAV 622 trekking	4028342 (W)	2	120 kg
<input type="checkbox"/> FUTOUR-610FX GTS 622 trekking	4028332 (M)	2	140 kg
<input type="checkbox"/> FUTOUR-610X WAV 622 trekking	4028322 (W)	2	140 kg
<input type="checkbox"/> FUTOUR-610X LDS 622 trekking	4028312 (L)	2	140 kg
<input type="checkbox"/> FUTOUR-610 WAV 622 trekking	4028412 (W)	2	140 kg
<input type="checkbox"/> FUTOUR-610 GTS 622 trekking	4028402 (M)	2	140 kg
<input type="checkbox"/> FUTOUR-609 WAV 622 trekking	4028302 (W)	2	140 kg
<input type="checkbox"/> FUTOUR-509 WAV 622 trekking	4028392 (W)	2	140 kg
<input type="checkbox"/> FUTOUR-508 WAV 622 trekking	4028382 (W)	2	140 kg
<input type="checkbox"/> ORAMA-605DX WAV 622 city	4028222 (W)	1	140 kg
<input type="checkbox"/> ORAMA-605N WAV 622 city	4028212 (W)	1	140 kg
<input type="checkbox"/> ORAMA-605C WAV 622 city	4028202 (W)	1	140 kg

> Chap. 7 on page 16 > Chap. 11 on page 27

Tyres

Rim size 27.5" 28" 29" Tyre size _____

Valve type (on delivery) Auto valve Express valve Presta valve

EPAC drive unit

Shimano STEPS DU-EP800 Shimano STEPS DU-E6100

Shimano STEPS DU-E6110 Shimano STEPS DU-E5000

EPAC display

Shimano STEPS SC-E7000 Shimano STEPS SC-E6100

Shimano STEPS SC-E5000

EPAC battery

Shimano BT-E8036, 630Wh, fully integrated Shimano BT-E8016, 630Wh, semi-integrated

Shimano BT-E8010, 504Wh, semi-integrated Shimano BT-E8014, 418Wh, semi-integrated

Shimano BT-E6000, 418Wh, carrier

Gear shift system

Derailleur system Hub shifting system

Lights

Carrier

rear Permitted load in kg: none

Stand

Side stand none

Child seat Trailer

Not permitted! Not permitted!

Competitions Bike parks

Not permitted! Not permitted!

Special features

Vehicle is **not** approved for use on public roads

Vehicle is approved for use on public roads, the following equipment has been fitted:

.....

.....

.....

Date, stamp/signature of specialist dealer:

HANDOVER CERTIFICATE

Specialist dealer

The handover of the pedelec indicated in the bicycle passport to the customer took place after:

- Final assembly of the pedelec,
- A check of all screw connections,
- A functional check of all components,
- The removal of excess oil and grease,
- A test ride,
- The pedelec had been adjusted to suit the customer,
- Training of the customer in correct use of the pedelec,
- The customer was advised to carry out an inspection after 500 km or 25-50 hours of use, but within two months of purchase at the latest,
- The customer was advised to read the original operating instructions and all related instructions for the components before first use.

Date, stamp/signature of specialist dealer:

Customer

Surname

First name

Street

Post code/city

- The bicycle passport has been filled out by the specialist dealer
- The pedelec has been adjusted to suit me
- I have been given an explanation of the basic operations of the pedelec
- The original operating instructions and all related manuals for the components have been handed over to me

Place, date

Signature of customer

